

OMRON

VT-WIN II

PRINTED CIRCUIT BOARD
INSPECTION SYSTEM

Second-Generation Advances
for Lead-Free Solder Inspection,
Micro Component Detection,
and Higher Throughput



CE
CE Conformed

*Innovation
in the Solution Age*

OMRON INDUSTRIAL AUTOMATION

Fully Automated and Integrated High-Speed, In-Line PCB Inspection System

Reliability and Flexibility to Handle Tomorrow's Challenges

Omron's new VT-WIN II offers advances in solder inspection, component fault detection and process speed that give you a competitive edge in **productivity, waste reduction and quality control**. First introduced in 1996, the original VT-WIN revolutionized in-line PCB inspection with a patented Color Highlight System and color image processing that positioned Omron as an industry leader in this category of quality improvement tools.

Advances Evolved for Changing Needs

The VT-WIN II delivers these major improvements:

- Angled-view inspection to detect lifted leads on gullwing devices and heel fillets on SOJ and PLCC devices
- Industry-leading algorithms to accurately inspect **lead-free solder**
- Four times the inspection area and twice the speed
- Automatic color extraction tool and other teaching aid functions dramatically reduce setup time

Omron's commitment to continuous improvement and innovation through R&D investment assures a steady stream of advancements to further automate and simplify the inspection process.

Maximizing All of Your Resources

Join the hundreds of foreign and domestic VT-System users and discover how our combination of powerful, easy-to-use software, unique inspection algorithms and the ability to perform 100% detailed inspections at production speeds can help your bottom line. We increase the speed of rework and repair by using fault images combined with the PCB map location for fault verification. The full color images captured during setup or operation can be further used for training and to improve the performance of your assembly operation. Both uses help maximize your production up-time and eliminate waste.

Where VT-WIN II Contributes Most

By integrating VT-WIN II into your process, you will improve production and inspection quality, verify process engineering and allow for a more efficient distribution of resources. The VT-WIN II inspection system offers benefits that will positively impact multiple areas in your process, including:

- Post Wave Solder
- Post Reflow

The VT-WIN II combines innovative technologies, unrivaled speed, easy-to-use functionality, and national and international support to deliver maximum benefits for your inspection operations.

Partial Client List

- Solectron
- Celestica
- Flextronics
- Kyocera
- Siemens
- Ford/Visteon
- Benchmark Electronics
- Sony
- Hitachi



Proven, Innovative Technology

Data Acquisition and Interpretation

Omron's patented Color Highlight System provides unparalleled inspection quality for both conventional solder joints and lead-free solder joints. Our system uses a multi-color LED light source to project red, green and blue light onto the PCB at different angles. The camera captures these colors as they reflect off the board's surface, producing a two-dimensional image that conveys three-dimensional information. This image allows the VT-WIN II to detect minute flaws that would ordinarily be missed. For an extensive list of faults detected, see the next page.

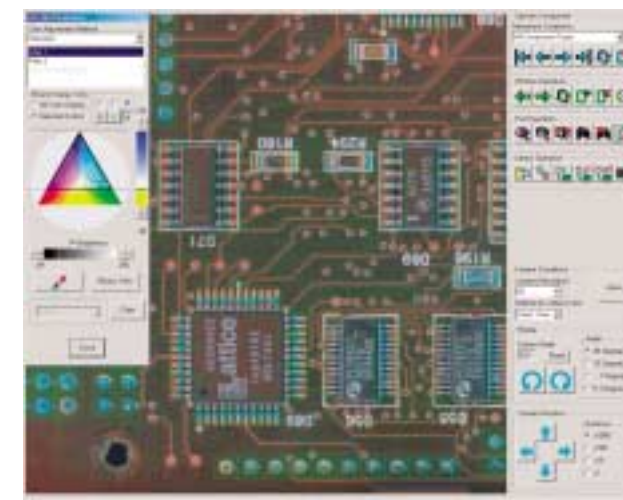
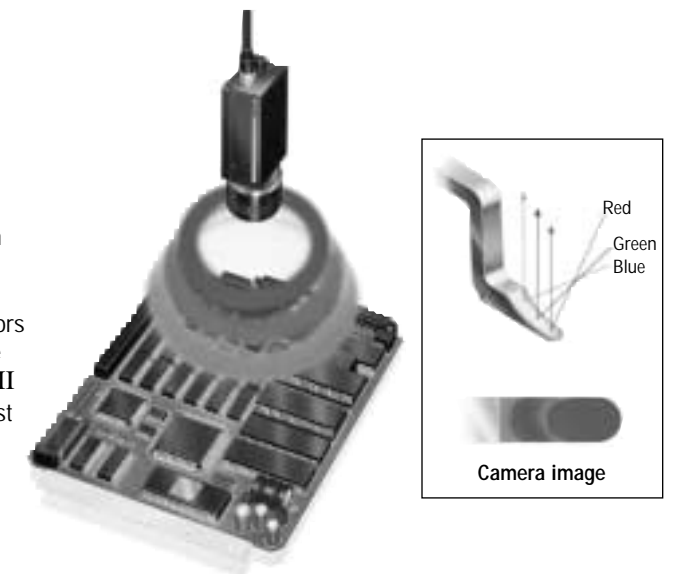

Color Extraction Process

The exclusive Color Extraction Process greatly simplifies system setup and customization of Omron's patented **Color Highlight System** for conventional or lead-free solder. The graphical user interface (GUI) Omron developed allows an operator to define color values by pointing to a desired object and assigning it a color with click of a mouse. Proven algorithms allow detection of a wide range of surface and reflective conditions, especially important with lead-free solder. Compared to gray-scale inspection methods, where solder fillet image settings are defined with numerical values for brightness and contrast, Omron's Color Extraction Process is significantly easier, reduces errors due to misinterpretation of data or colors, and ultimately reduces start-up time.

Angled View Inspection

Gullwing lead pitches are getting smaller, and many PCB designs are using SOJ and PLCC devices to maximize board real estate through increased density. These instances present a particular challenge to accurate automatic detection of solder fillets and lead lifting. Omron's exclusive angled-view inspection lets you look around at a 20-degree angle. Improved inspection algorithms, including user-customized ones, ensure reliable results from the most challenging board layouts. Compare the image detail from conventional orthogonal inspection to the extensive detail of Omron's angled view.

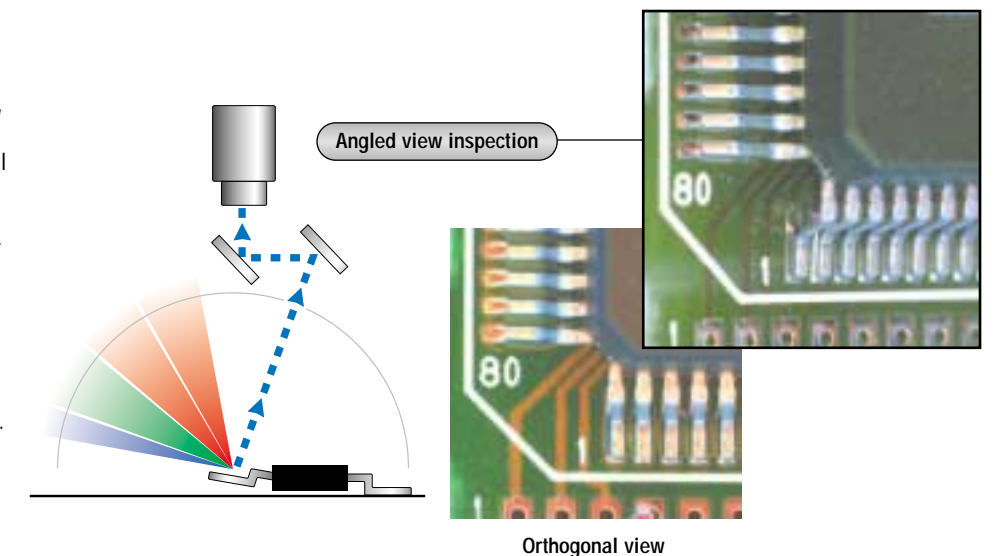

High Speed

PCB Magnification and Inspection Speed

Eight Magnification Levels Match Component Size

For maximum speed and efficiency in inspecting PCBs with varying component densities, the VT-WIN II has eight different magnification levels: 10, 13, 15, 20, 25, 30, 35 and 50 μm resolutions. The standard power zoom lens allows the operator to customize the inspection depending on the individual component size. At 10 μm resolution, it is possible to perform 0.3 mm pitch QFP (quad flat pack) and 0603 mm (0201 inch) chip component inspections accurately. The zoom lens allows any three different magnifications to be used when inspecting PCBs. The VT-WIN II automatically changes magnifications among programmed selections to maximize inspection speed.

Larger Image Area for Faster Inspections

To keep in step with tomorrow's high-speed processing Omron's VT-WIN II uses a high resolution, triple element CCD camera with four times the image area of previous models. Inspection speed is effectively doubled, too. This reduces the number of views per board to program, further speeding both in-line and off-line processes.

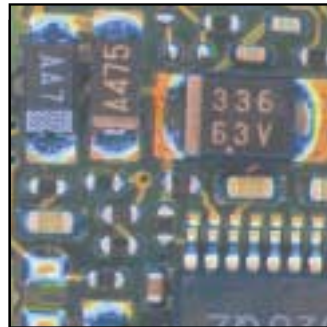

VT-WIN II:
Four times the image area

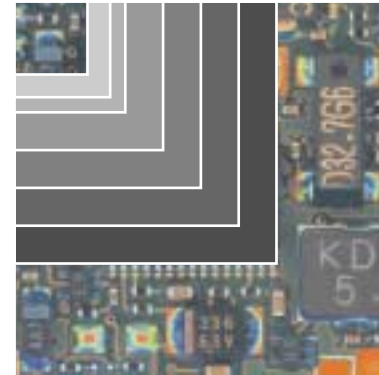
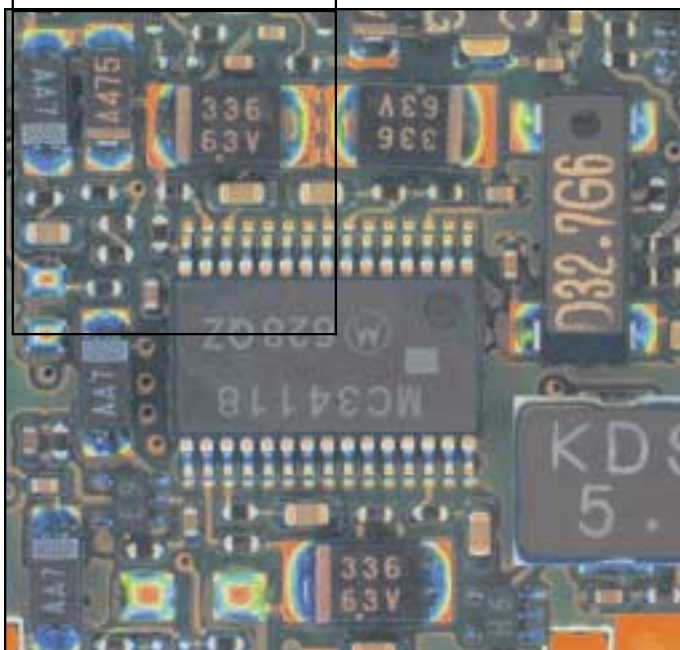

Eight magnification levels
between 10 and 50 μm resolution

Advanced Fault Detection

The VT-WIN II can inspect solder and component defects on virtually all types of wave and reflow components, including J-lead devices and rotated components with options.

Defects the VT-WIN II can detect include:

Solder defects:

- Bridging
- Wettability
- Presence/absence
- Excessive Solder
- Insufficient Solder
- Blow Holes
- Solder Balls

Component defects

- Presence/absence
- Shift
- Lifting
- Un-inserted
- Upside-down/backward
- Polarity marking
- Pin one marking
- Component marking
- Bent leads
- Tombstone

Ease of Use

Simple Setup

Operators can quickly set up and teach the VT-WIN II new inspection programs using Omron's library-based programming methods. For each type of component used (transistors, QFPs chip components, etc.), the VT-WIN II provides a generic inspection model with graphic elements that allow easy re-shaping to match the exact part. Use the generic model to create specific component variations in use on the PCB; then name and store it in the library.

Determining Component Placement

At the next stage each component variation gets placed where it appears on a board. This can be done manually, but Omron automates this labor-intensive step by merging your CAD or Gerber data with the component library using our Teaching Interface Software. This automatically creates the inspection program by assigning the right part variations to their locations. Omron drivers are available from common CAD management software packages such as AEGIS CircuitCAM and Tecnomatix. The information used from the component placement data includes:

- Component type
- Component reference designator
- X-Y centroid
- Theta rotation

Programs can be created offline to maximize up-time and performance.

Setting Inspection Parameters

The user can adjust the sizes of inspection windows and color variations of each inspection item (solder joint, component body color, placement markings, etc.) from a camera image of the component displayed on the monitor. The last step requires the operator to tune the acceptability criteria using additional production boards.

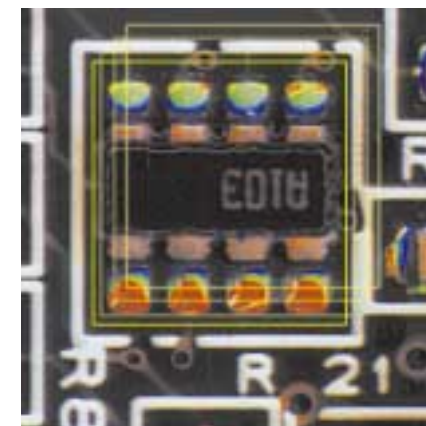

Automatic Window Position Adjustment

The VT-WIN II can automatically adjust for small changes in component location and position compared to inspection window location. If the inspection model is not where it should be, the system automatically locates the component lands, and repositions the inspection model. This feature, exclusive to the VT-WIN II, increases accuracy while decreasing teaching time.

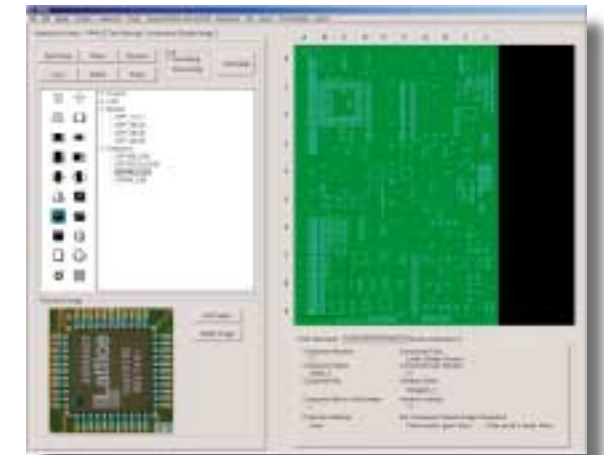

Component Library

Hardware/Software Options

Networking and Data Usage

The VT-Systems family encompasses all the products necessary to maintain an efficient PCB inspection process. They communicate via Ethernet, RS-232C and SMEMA to exchange important production data from one end of the process to the other.

ORION Repair Station Software

Use this optional software to take the guesswork out of making delicate repairs on densely populated PCBs. It automatically prepares a list of parts, locations and types of faults on a PCB and shows them on a map. VT-WIN II makes fault identification easier by storing a high-resolution color image of the defective location, so finding the part for repair is faster and more accurate. Data about the repair, the technicians involved, and more can be stored to a database for future analysis and quality control needs.

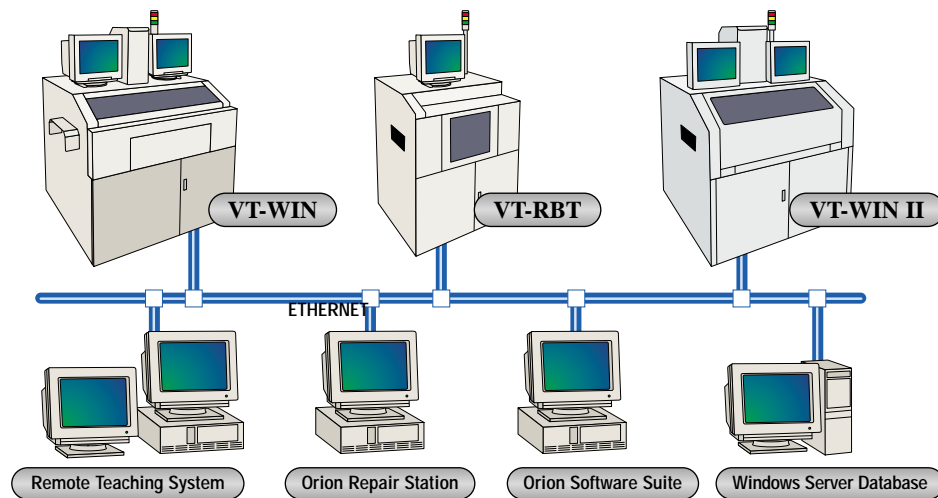

ORION—The Complete Software Suite

Omron offers three modules to optimize usage of data gathered from PCB and solder inspection. They are Data Monitor, Data Analysis and Data Manager. Used together these software modules obtain various types of manufacturing information in real time. The software can monitor the operating status of multiple VT-Systems simultaneously. It can also track the amount and type of defects, using stored inspection results to identify manufacturing trends. The information obtained can be displayed to reflect the entire production process or tailored to show the performance of individual VT-Systems.



Remote Teaching Software

Improve machine up-time by programming VT-WIN II offline using Omron's Remote Teaching Software (RTS). It can acquire images from the VT-WIN II via an Ethernet connection or magnetic optical disk and process and interpret the images using the Teaching Interface Software. Use the images for remote programming and off-site training.

VT-WIN II System Specifications

HARDWARE SPECIFICATIONS

Image Signal Input Unit	Video Camera	Triple Element CCD Camera
	Light Source	3 Ring-Shaped LED arrays with automatic brightness control
	Image Resolution	10, 13, 15, 20, 25, 30, 35, 50 μ m
Main Unit	PCB Handling	Edge Belt Conveyor
	Rail Conveyor Width Adjustment	Automatic
PCB Fixturing Method	Outer Frame	
PCB Support	To avoid the effect of bending PCB, support pins can be attached.	
Power Supply	AC200V, 3kw 5minutes UPS	
Air	0.4 to 0.6 MPa (60 to 90 PSI)	
Room Temperature	10° to 35°C (50° to 95°F)	
Room Humidity	30 to 80% RH	
Weight	Medium Under 1350 kg (2970 lbs)	Large Under 1700 kg (3740 lbs)
Dimensions	Medium	1253 W x 1203 D x 1910 H mm (49.33 W x 47.36 D x 75.20 H in)
	Large	1503 W x 1507 D x 1910 H mm (59.17 W x 59.33 D x 75.20 H in)

OPTIONS

J/Angle View	Inspection for J-lead components such as PLCC, SOJ, etc.
OCV/OCR	Inspect components by checking characters on the component.

FUNCTION SPECIFICATIONS

Inspectable PCBs	Solder Process	Wave and reflow; lead or lead-free solder
	Board Sizes	Medium frame: 50x80mm(1.96 x 3.14 in)up to 255x333mm(10.02x13.08 in) Large frame: 50x80mm(1.96x3.14 in) up to 460x510mm(18.11x20.08 in)
	PCB Thickness	0.3 to 4.0 mm (0.01 to 0.16 in)
Camera Clearance	50 mm (1.97 in) both above and below the PCB	
Inspectable Components	Square Chips	0603 mm (0201 in) packages and up
	LSI	0.3 mm (0.01 in) pitch and up
	Others	Special-shaped components, through-hole components
Inspection Categories	Solder Defects	Bridging, Wettability, Presence/absence, Excessive Solder, Insufficient Solder, Blow Holes, Solder Balls
	Component Defects	Presence/absence, Shift, Lifting, Un-inserted, Upside-down/backward, Polarity marking, Pin one marking, Component marking, Bent leads, Tombstone
Number of Inspection Points	Up to 10,000 components/PCB	
Data Storage	40 GB hard disk, 1.3 GB magneto-optical	
Component Data Library	Up to 999 variation/component types	
Inspection Results Output	Faulty component name, faulty pin number, type of fault, PCB graphic (printer, monitor)	
Standard Inspection Speed	400 msec/screen	
Communications	Ethernet, RS-232C, SMEMA	
Process Change	Automatic rail width adjustment	
Process Flow Direction	Through or Turn Back	
Position Standard	Left or Right, Front or Back; selectable before shipping.	

VT-WIN II

Dimensions Unit: mm (inch)

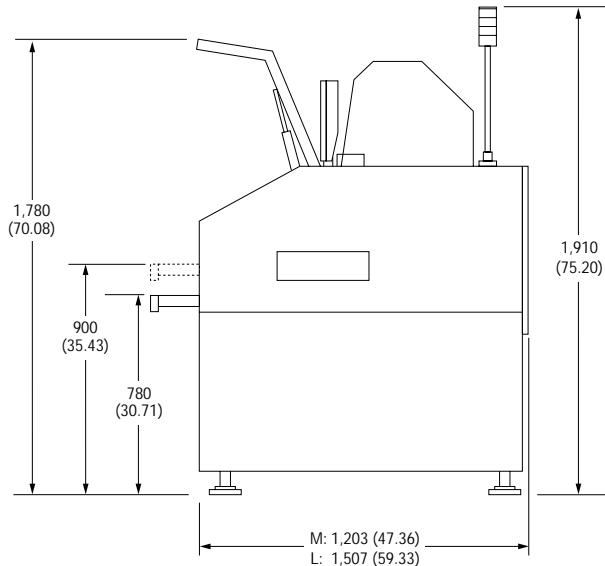
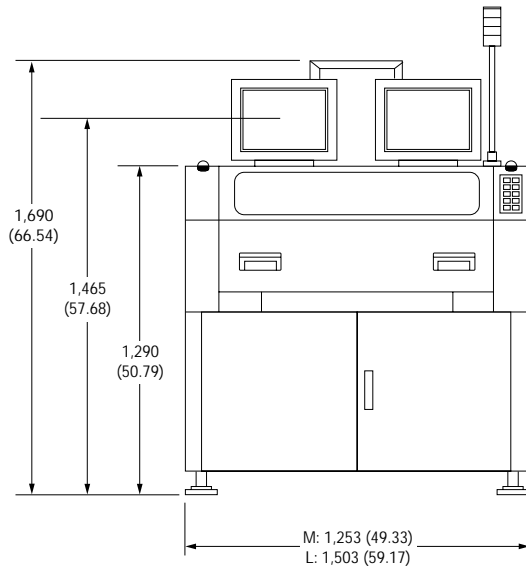

OMRON Corporation,
Mishima Factory received ISO-14001 certification.

OMRON Corporation,
INDUSTRIAL AUTOMATION COMPANY,
SENSING DEVICES AND COMPONENTS DIVISION H.Q.,
VISION SYSTEMS BUSINESS DEIVISION received ISO-9001 certification.

PATENT Information

OMRON has many patents for PCB solder inspection systems.
Approved: 40 Pending: 200

- ⊙The screens shown here were produced artificially. As the software used for the image photos is for demonstration purposes only, it is not included.
- ⊙This catalog has concerned itself primarily with aiding in system selection, and all safety and cautionary categories were not included. To learn more about the safety considerations when using the VT-WIN, please consult the user's manual.
- ⊙For anyone planning to use the VT-WIN under any conditions or environments not listed in this catalog, or in any industry such as atomic energy control, railways, airports, automobiles, flammable equipment, medical equipment, entertainment equipment, safety equipment, or any other area which has a large effect on life and property and requires a great degree of safety, we ask you to take special care vis-a-vis the ratings and characteristics of this machine and to implement failsafe procedures, and also to contact your sales representative and confirm your configuration with him/her.

OMRON

JAPAN H.Q.

JAPAN

Omron Corporation
Vision System Division
Overseas Business Group
1-11-1, Ohsaki, Shinagawa-ku,
Tokyo, 141-0032 JAPAN
Tel: (+81) 3-3779-9045
Fax: (+81) 3-3779-9041

EUROPE

THE UNITED KINGDOM
Omron Electronics Limited
1 Apsley Way, Staples Corner
London NW2 7HF, UK
Tel: (+44) 20-8450-4646 Fax: (+44) 20-8450-8087

FRANCE
Omron Electronics S.a.r.l.
B-timent C, Rue G. Marconi
44812 Saint Herblain Cedex, FRANCE
Tel: (+33) 2-51805370 Fax: (+33) 2-51807039

ASIA

SINGAPORE/INDONESIA/
PHILIPPINES/VIETNAM
Omron Electronics Pte. Ltd.
55Ubi Avenue 1 05-01, Singapore 408935, SINGAPORE
Tel: (+65) 647-6789 Fax: (+65) 647-6766

THAILAND
Omron Electronics Co., Ltd.
Rasa Tower 20th Floor, 555 Phaholyothin Rd.,
Chatuchak, Bangkok 10900, THAILAND
Tel: (+66) 2-937-0500 Fax: (+66) 2-937-0501

MALAYSIA
Omron Electronics Sdn. Bhd.
2.01, Level 2, Wisma Academy, 4A,
Jalan 19/1, 46300 Petaling Jaya,
Selangor Darul Ehsan MALAYSIA
Tel: (+60) 3-7954-7323 Fax: (+60) 3-7954-6618

AUSTRALIA
Omron Electronics Pty. Ltd.
71 Epping Road North Ryde,
Sydney NSW2113 AUSTRALIA
Tel: (+61) 2-9878-6377 Fax: (+61) 2-9878-6981

KOREA
KL TECH Corporation
4F-405, i ten ten B/D, 1009-1,
Youngtong-Dong, Paldal-Gu,
Suwon-Si, Kyunggi-Do, 442-813, KOREA
Tel: (+82) 31-206-5700 Fax: (+82) 31-206-5706

CHINA

CHINA (Beijing)
Omron (China) Co., Ltd.
Room 1024, Office Building,
Beijing Capital Times Square
No.88 West Chang 'an Ave.,
Beijing 100031, CHINA
Tel: (+86) 10-83913011 Fax: (+86) 10-83913232

CHINA (Shanghai)
Omron (China) Co., Ltd.
Room 2211, Bank of China Tower,
200, Yin Cheng Zhong Road,
Pu Dong New Area, Shanghai, 200120, CHINA
Tel: (+86) 21-5037-2222 Fax: (+86) 21-5037-2200

CHINA (Shenzhen)
Omron Trading (Shenzhen) Co., Ltd.
112-115, Block 1, 1001
Honghua RD., Futian Free Trade Zone,
Shenzhen 518038, CHINA
Tel: (+86) 755-359-9028 ext.227
Fax: (+86) 755-359-9628

TAIWAN
Omron Taiwan System Inc.
11F, No8, Sec.1, Jungshiau W.Road,
Taipei, TAIWAN R.O.C
Tel: (+886) 2-2375-2200 Fax: (+886) 2-2375-2233

AMERICA

THE UNITED STATES
Omron Electronics LLC
1 East Commerce Drive,
Schaumburg, Illinois 60173-5302, U.S.A.
Tel: (+1) 847-843-7852 Fax: (+1) 847-839-2159

CANADA
Omron Canada Inc.
885 Milner Avenue Toronto, Ontario M1B 5V8,
CANADA
Tel: (+1) 416-286-6465
Direct Voice: (+1) 416-208-4916
Fax: (+1) 416-286-6648