



## ■ Accessories (Order Separately)

### Sockets

Poles	Front-mounting Socket (DIN-track/ screw mounting)	Back-mounting Socket				
		Solder terminals		Wire-wrap terminals		PCB terminals
		Without clip	With clip	Without clip	With clip	
2	PYF08A-E PYF08A-N	PY08	PY08-Y1	PY08QN PY08QN2	PY08QN-Y1 PY08QN2-Y1	PY08-02
4	PYF14A-E PYF14A-N	PY14	PY14-Y1	PY14QN PY14QN2	PY14QN-Y1 PY14QN2-Y1	PY14-02

### Socket Hold-down Clip Pairing

Relay type	Poles	Front-connecting Socket (DIN-track/ screw mounting)		Back-connecting Socket			
				Solder/Wire-wrap terminals		PCB terminals	
		Socket	Clip	Socket	Clip	Socket	Clip
Without 2-pole test button	2	PYF08A-E PYF08A-N	PYC-A1	PY08(QN)	PYC-P PYC-P2	PY08-02	PYC-P PYC-P2
	4	PYF14A-E PYF14A-N		PY14(QN)		PY14-02	
2-pole test button	2	PYF08A-E PYF08A-N	PYC-E1	PY08(QN)	PYC-P2	PY08-02	PYC-P2

### Mounting Plates for Sockets

Socket model	For 1 Socket	For 18 Sockets	For 36 Sockets
PY08, PY08QN(2), PY14, PY14QN(2)	PYP-1	PYP-18	PYP-36

**Note:** PYP-18 and PYP-36 can be cut into any desired length in accordance with the number of Sockets.

### Track and Accessories

Supporting Track (length = 500 mm)	PFP-50N
Supporting Track (length = 1,000 mm)	PFP-100N, PFP-100N2
End Plate	PFP-M
Spacer	PFP-S

## Specifications

### ■ Coil Ratings

Rated voltage	Rated current		Coil resistance	Coil inductance (reference value)		Must operate voltage	Must release voltage	Max. voltage	Power consumption (approx.)	
	50 Hz	60 Hz		Arm. OFF	Arm. ON					
AC	6 V*	214.1 mA	183 mA	12.2 Ω	0.04 H	0.08 H	80% max.	30% min.	110%	1.0 to 1.2 VA (60 Hz)
	12 V	106.5 mA	91 mA	46 Ω	0.17 H	0.33 H				
	24 V	53.8 mA	46 mA	180 Ω	0.69 H	1.30 H				
	48/50 V*	24.7/ 25.7 mA	21.1/ 22.0 mA	788 Ω	3.22 H	5.66 H				
	110/120 V	9.9/10.8 mA	8.4/9.2 mA	4,430 Ω	19.20 H	32.1 H				
	220/240 V	4.8/5.3 mA	4.2/4.6 mA	18,790 Ω	83.50 H	136.4 H				
DC	6 V*	151 mA		39.8 Ω	0.17 H	0.33 H	10% min.		0.9 W	
	12 V	75 mA		160 Ω	0.73 H	1.37 H				
	24 V	37.7 mA		636 Ω	3.20 H	5.72 H				
	48 V*	18.8 mA		2,560 Ω	10.60 H	21.0 H				
	100/110 V	9.0/9.9 mA		11,100 Ω	45.60 H	86.2 H				

**Note:** 1. The rated current and coil resistance are measured at a coil temperature of 23°C with tolerances of +15%/–20% for rated currents and ±15% for DC coil resistance.

2. Performance characteristic data are measured at a coil temperature of 23°C.

3. AC coil resistance and impedance are provided as reference values (at 60 Hz).

4. Power consumption drop was measured for the above data. When driving transistors, check leakage current and connect a bleeder resistor if required.

5. Rated voltage denoted by "\*" will be manufactured upon request. Ask your OMRON representative.

## Contact Ratings

Item	2-pole		4-pole		4-pole (bifurcated)	
	Resistive load ( $\cos\phi = 1$ )	Inductive load ( $\cos\phi = 0.4, L/R = 7\text{ ms}$ )	Resistive load ( $\cos\phi = 1$ )	Inductive load ( $\cos\phi = 0.4, L/R = 7\text{ ms}$ )	Resistive load ( $\cos\phi = 1$ )	Inductive load ( $\cos\phi = 0.4, L/R = 7\text{ ms}$ )
Rated load	5A, 250 VAC 5A, 30 VDC	2A, 250 VAC 2 A, 30 VDC	3 A, 250 VAC 3 A, 30 VDC	0.8 A, 250 VAC 1.5 A, 30 VDC	3 A, 250 VAC 3 A, 30 VDC	0.8 A, 250 VAC 1.5 A, 30 VDC
Carry current	10 A (see note)		5 A (see note)			
Max. switching voltage	250 VAC 125 VDC		250 VAC 125 VDC			
Max. switching current	10 A		5 A			
Max. switching power	2,500 VA 300 W	1,250 VA 300 W	1,250 VA 150 W	500 VA 150 W	1,250 VA 150 W	500 VA 150 W
Failure rate (reference value)	5 VDC, 1 mA		1 VDC, 1 mA		1 VDC, 100 $\mu$ A	

**Note:** Don't exceed the carry current of a Socket in use. Please see page 57.

## Characteristics

Item	All Relays
Contact resistance	100 m $\Omega$ max.
Operate time	20 ms max.
Release time	20 ms max.
Max. operating frequency	Mechanical: 18,000 operations/hr Electrical: 1,800 operations/hr (under rated load)
Insulation resistance	1,000 M $\Omega$ min. (at 500 VDC)
Dielectric strength	2,000 VAC, 50/60 Hz for 1.0 min (1,000 VAC between contacts of same polarity)
Vibration resistance	Destruction: 10 to 55 to 10 Hz, 0.5 mm single amplitude (1.0 mm double amplitude) Malfunction: 10 to 55 to 10 Hz, 0.5 mm single amplitude (1.0 mm double amplitude)
Shock resistance	Destruction: 1,000 m/s <sup>2</sup> Malfunction: 200 m/s <sup>2</sup>
Endurance	See the following table.
Ambient temperature	Operating: -55°C to 70°C (with no icing)
Ambient humidity	Operating: 5% to 85%
Weight	Approx. 35 g

**Note:** The values given above are initial values.

## Endurance Characteristics

Pole	Mechanical life (at 18,000 operations/hr)	Electrical life (at 1,800 operations/hr under rated load)
2-pole	AC:50,000,000 operations min.	500,000 operations min.
4-pole	DC:100,000,000 operations min.	200,000 operations min.
4-pole (bifurcated)	20,000,000 operations min.	100,000 operations min.

■ Approved Standards

**VDE Recognitions (File No. 112467UG, IEC 255, VDE 0435)**

No. of poles	Coil ratings	Contact ratings	Operations
2	6, 12, 24, 48/50, 100/110 110/120, 200/220,	10 A, 250 VAC (cosφ=1) 10 A, 30 VDC (L/R=0 ms)	10 x 10 <sup>3</sup>
4	220/240 VAC 6, 12, 24, 48, 100/110, 125 VDC	5 A, 250 VAC (cosφ=1) 5 A, 30 VDC (L/R=0 ms)	100 x 10 <sup>3</sup> MY4Z AC; 50 x 10 <sup>3</sup>

**UL508 Recognitions (File No. 41515)**

No. of poles	Coil ratings	Contact ratings	Operations
2	6 to 240 VAC 6 to 125 VDC	10 A, 30 VDC (General purpose) 10 A, 250 VAC (General purpose)	6 x 10 <sup>3</sup>
4		5 A, 250 VAC (General purpose) 5 A, 30 VDC (General purpose)	

**CSA C22.2 No. 14 Listings (File No. LR31928)**

No. of poles	Coil ratings	Contact ratings	Operations
2	6 to 240 VAC 6 to 125 VDC	10 A, 30 VDC 10 A, 250 VAC	6 x 10 <sup>3</sup>
4		5 A, 250 VAC (Same polarity) 5 A, 30 VDC (Same polarity)	

**IMQ (File No. EN013 to 016)**

No. of poles	Coil ratings	Contact ratings	Operations
2	6, 12, 24, 48/50, 100/110 110/120, 200/220, 220/240 VAC	10 A, 30 VDC 10 A, 250 VAC	10 x 10 <sup>3</sup>
4		5 A, 250 VAC 5 A, 30 VDC	100 x 10 <sup>3</sup> MY4Z AC; 50 x 10 <sup>3</sup>

**LR Recognitions (File No. 98/10014)**

No. of poles	Coil ratings	Contact ratings	Operations
2	6 to 240 VAC 6 to 125 VDC	10 A, 250 VAC (Resistive) 2 A, 250 VAC (PF0.4) 10 A, 30 VDC (Resistive) 2 A, 30 VDC (L/R=7 ms)	50 x 10 <sup>3</sup>
4		5 A, 250 VAC (Resistive) 0.8 A, 250 VAC (PF0.4) 5 A, 30 VDC (Resistive) 1.5 A, 30 VDC (L/R=7 ms)	50 x 10 <sup>3</sup>

**SEV Listings (File No. 99.5 50902.01)**

No. of poles	Coil ratings	Contact ratings	Operations
2	6 to 240 VAC 6 to 125 VDC	10 A, 250 VAC 10 A, 30 VDC	10 x 10 <sup>3</sup>
4		5 A, 250 VAC 5 A, 30 VDC	100 x 10 <sup>3</sup> MY4Z AC; 50 x 10 <sup>3</sup>

# Engineering Data

## Maximum Switching Power

MY2

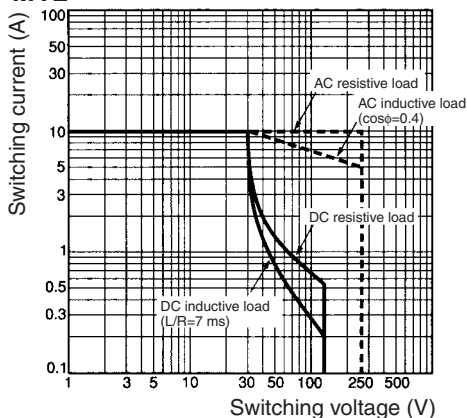

MY4, MY4Z

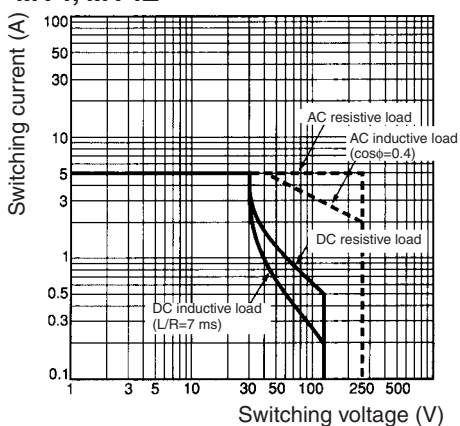

## Endurance

MY2 (Resistive Loads)

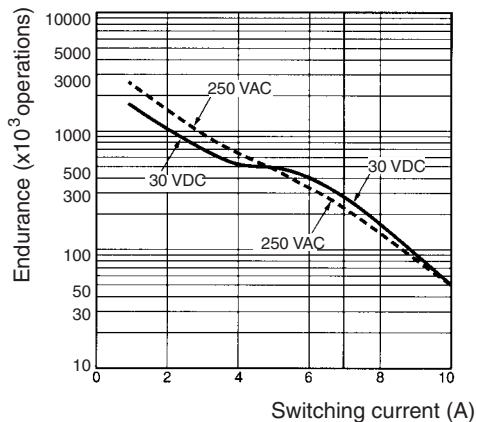

MY2 (Inductive Loads)

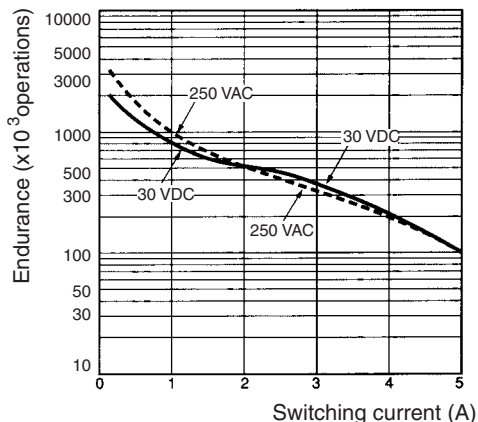

MY4 (Resistive Loads)

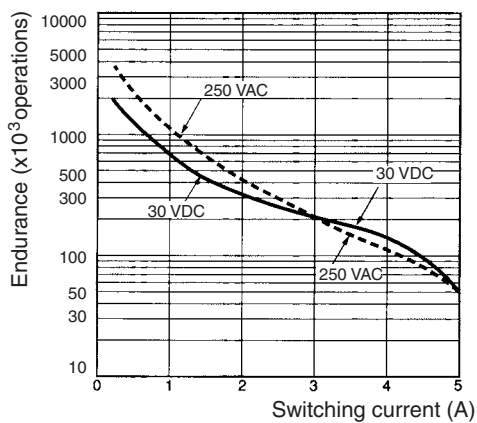

MY4 (Inductive Loads)

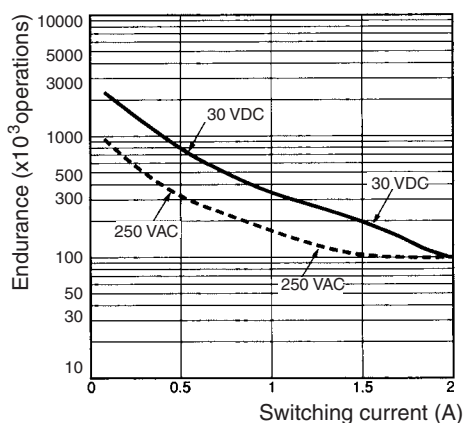

**MY4Z (Resistive Loads)**

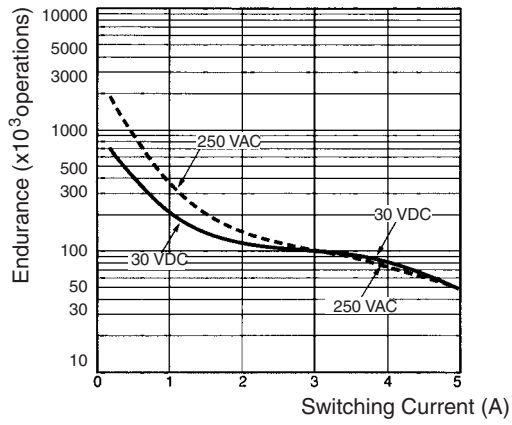

**MY4Z (Inductive Loads)**

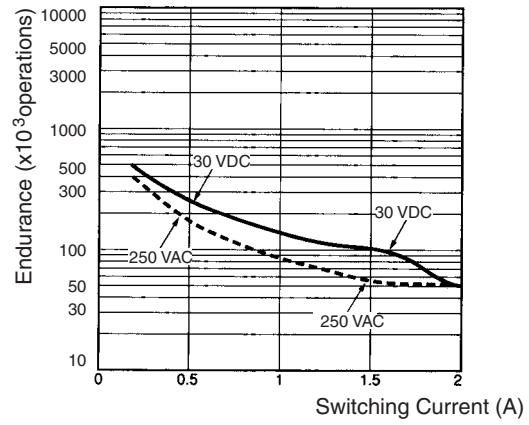

# Dimensions

Note: All units are in millimeters unless otherwise indicated.

## 2-Pole Models

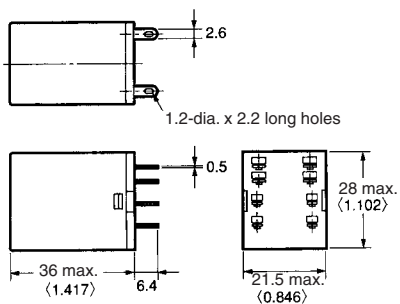
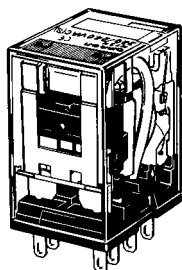

## 4-Pole Models

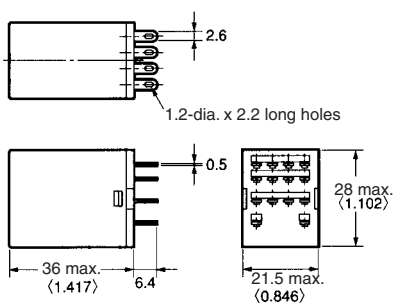
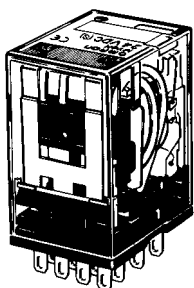

## Models with Test Button

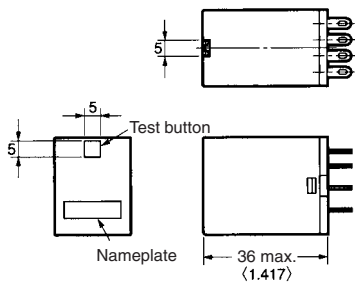
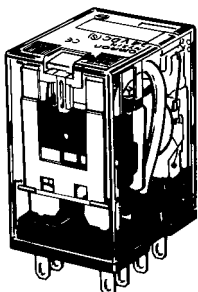

# Terminal Arrangement/Internal Connections (Bottom View)

MY2

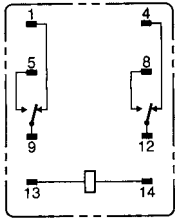

MY2N/MY2IN  
(AC Models)

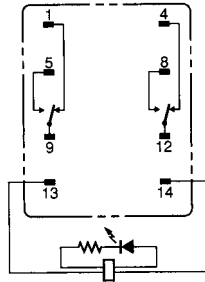

MY2N/MY2IN  
(DC Models)

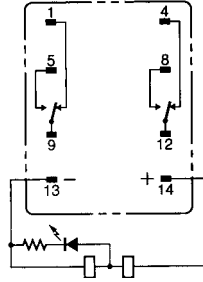

MY2N-D2/MY2IN-D2  
(DC Models Only)

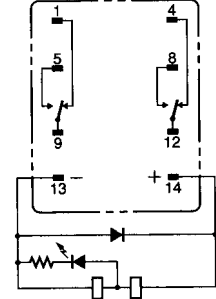

MY2N-CR/MY2IN-CR  
(AC Models Only)

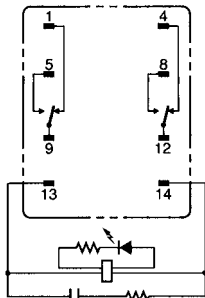

MY2N1/MY2IN1  
(DC Models Only)

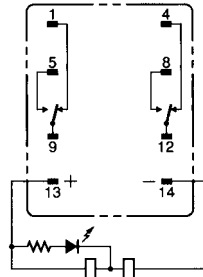

MY2N1-D2/MY2IN1-D2  
(DC Models Only)

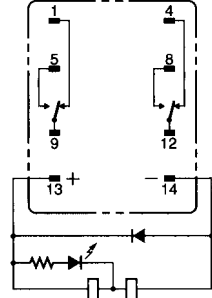

MY4(Z)

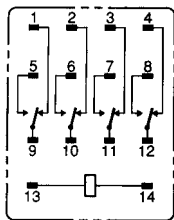

MY4(Z)N/MY4(Z)IN  
(AC Models)

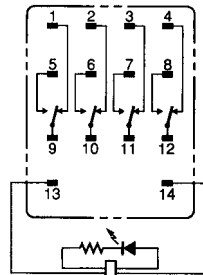

MY4(Z)N/MY4(Z)IN  
(DC Models)

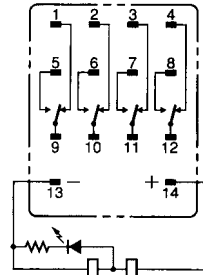

MY4(Z)N-D/MY4(Z)IN-D2  
(DC Models Only)

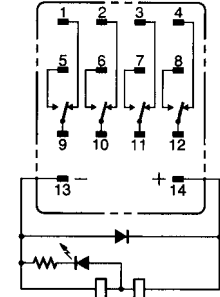

MY4(Z)N-CR/MY4(Z)IN-CR  
(AC Models Only)

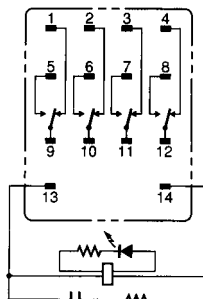

MY4(Z)N1/MY4(Z)IN1  
(DC Models Only)

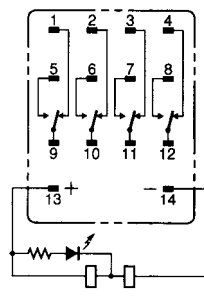

MY4(Z)N1-D2/MY4(Z)IN1-D2  
(DC Models Only)

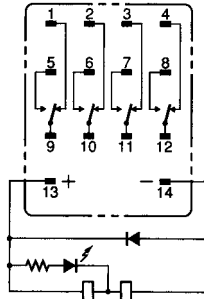

Note: The DC models have polarity.

# Socket for MY

## Track-mounted (DIN Track) Socket Conforms to VDE 0106, Part 100

- Snap into position along continuous sections of any mounting track.
- Facilitates sheet metal design by standardized mounting dimensions.
- Design with sufficient dielectric separation between terminals eliminates the need of any insulating sheet.

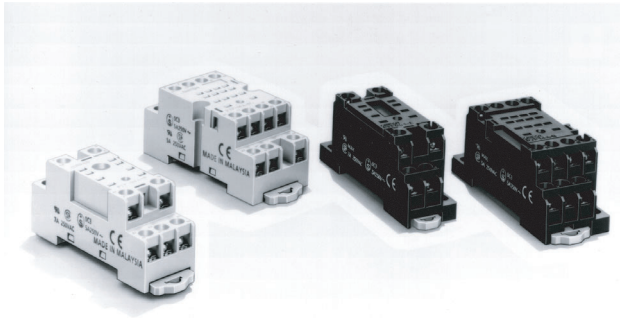

### ■ Safety Standards for Sockets

Model	Standards	File No.
PYF08A-E, PYF08A-N	UL508	E87929
PYF14A-E, PYF14A-N	CSA22.2	LR31928

### Back-connecting Sockets

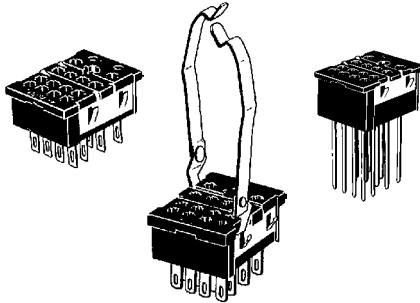

### ■ Specifications





Item	Pole	Model	Carry current	Dielectric withstand voltage	Insulation resistance (see note 2)
Track-mounted Socket	2	PYF08A-E	7 A	2,000 VAC, 1 min	1,000 MΩ min.
		PYF08A-N (see note 3)	7 A (see note 4)		
	4	PYF14A-E	5 A		
		PYF14A-N (see note 3)	5 A (see note 4)		
Back-connecting Socket	2	PY08(-Y1)	7 A	1,500 VAC, 1 min	100 MΩ min.
		PY08QN(-Y1)			
		PY08-02			
	4	PY14(-Y1)	3 A		
		PY14QN(-Y1)			
		PY14-02			

- Note:**
1. The values given above are initial values.
  2. The values for insulation resistance were measured at 500 V at the same place as the dielectric strength.
  3. The maximum operating ambient temperature for the PYF08A-N and PYF14A-N is 55°C.
  4. When using the PYF08A-N or PYF14A-N at an operating ambient temperature exceeding 40°C, reduce the current to 60%.

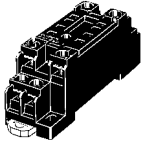
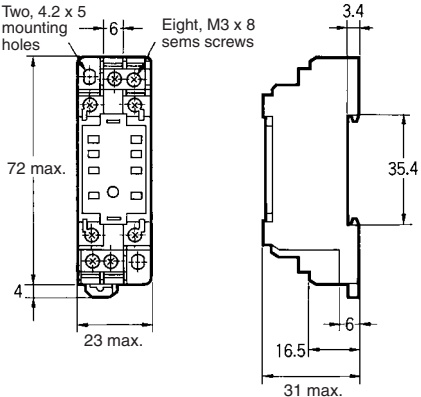
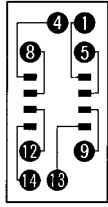
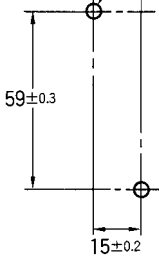
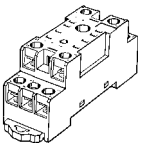
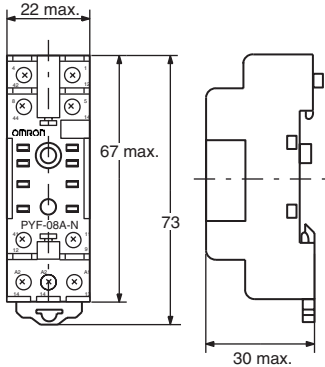
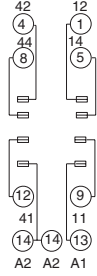
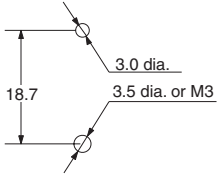
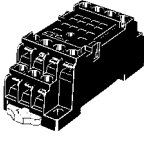
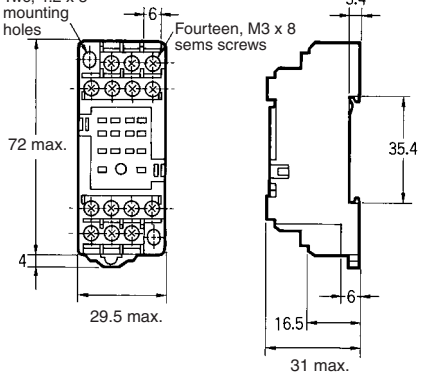
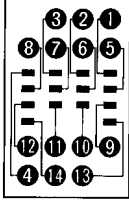
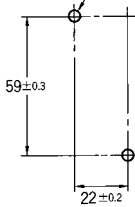
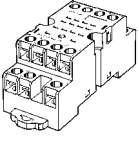
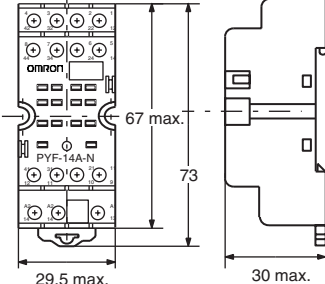
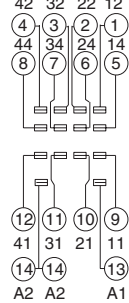
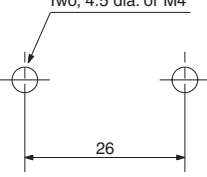
## ■ Dimensions

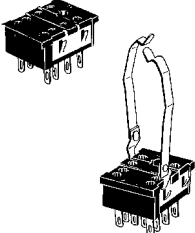
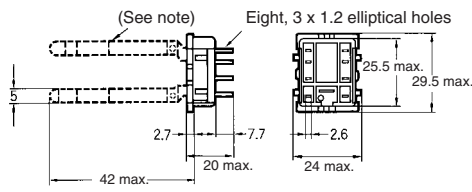
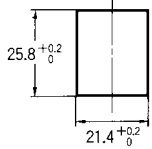
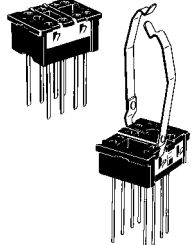
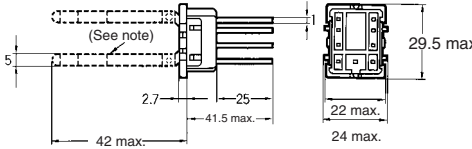
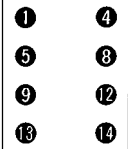
Note: All units are in millimeters unless otherwise indicated.

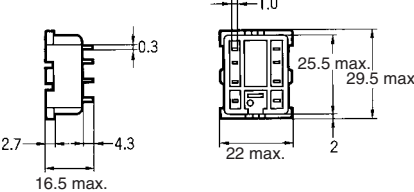
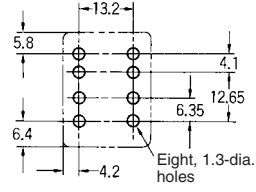
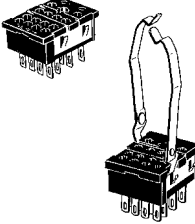
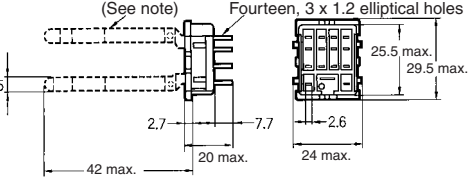
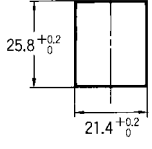
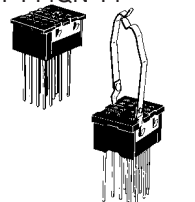
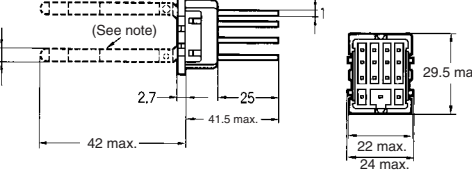
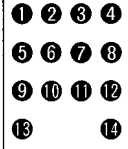
Socket	Dimensions	Terminal arrangement/ Internal connections (top view)	Mounting holes
 <p>PYF08A-E</p>	 <p>Two, 4.2 x 5 mounting holes Eight, M3 x 8 sems screws 72 max. 4 23 max. 6 3.4 35.4 16.5 6 31 max.</p>		<p>Two, M3, M4, or 4.5-dia. holes</p>  <p>59±0.3 15±0.2 (TOP VIEW)</p> <p>Note: Track mounting is also possible. Refer to page 12 for supporting tracks.</p>
 <p>PYF08A-N</p>	 <p>22 max. 67 max. 73 30 max.</p>	 <p>42 12 4 1 44 14 8 5 12 9 41 11 14 14 13 A2 A2 A1</p>	 <p>3.0 dia. 3.5 dia. or M3 18.7 Note: Track mounting is also possible. Refer to page 12 for supporting tracks.</p>
 <p>PYF14A-E</p>	 <p>Two, 4.2 x 5 mounting holes Fourteen, M3 x 8 sems screws 72 max. 4 29.5 max. 6 3.4 35.4 16.5 6 31 max.</p>		<p>Two, M3, M4, or 4.5-dia. holes</p>  <p>59±0.3 22±0.2 (TOP VIEW)</p> <p>Note: Track mounting is also possible. Refer to page 12 for supporting tracks.</p>
 <p>PYF14A-N</p>	 <p>67 max. 73 29.5 max. 30 max.</p>	 <p>42 32 22 12 4 3 2 1 44 34 24 14 8 7 6 5 12 11 10 9 41 31 21 11 14 14 13 A2 A2 A1</p>	<p>Two, 4.5 dia. or M4</p>  <p>26 Note: Track mounting is also possible. Refer to page 12 for supporting tracks.</p>

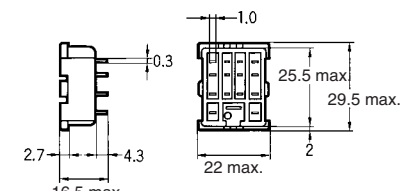
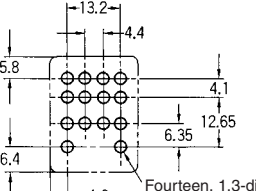
Socket	Dimensions	Terminal arrangement/ Internal connections (bottom view)	Mounting holes
<p>PY08/PY08-Y1</p> 	 <p><b>Note:</b> The PY08-Y1 includes sections indicated by dotted lines.</p>		
<p>PY08QN/ PY08QN-Y1</p> 	 <p><b>Note:</b> The PY08QN-Y1 includes sections indicated by dotted lines.</p>		
<p>PY08-02</p> 			
<p>PY14/PY14-Y1</p> 	 <p><b>Note:</b> The PY14-Y1 includes sections indicated by dotted lines.</p>		
<p>PY14QN/ PY14QN-Y1</p> 	 <p><b>Note:</b> The PY14QN-Y1 includes sections indicated by dotted lines.</p>		
<p>PY14-02</p> 			

**Note:** Use a panel with plate thickness of 1 to 2 mm for mounting the Sockets.

## Hold-down Clips

**PYC-A1**  
(2 pcs per set)

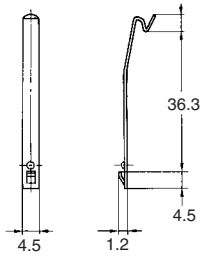

**PYC-E1**  
(2 pcs per set)

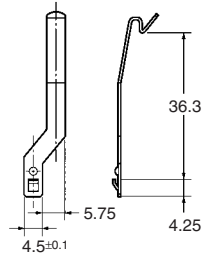

**PYC-P**

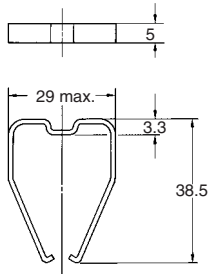

**PYC-P2**

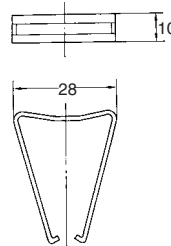

## Mounting Plates for Back-connecting Sockets

**PYP-1**

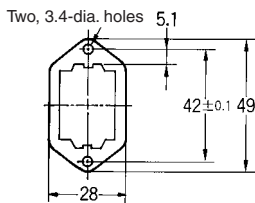

t=1.6

**PYP-36**

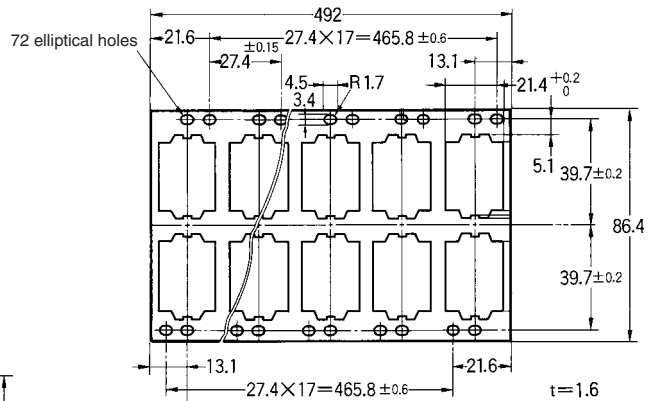

**PYP-18**

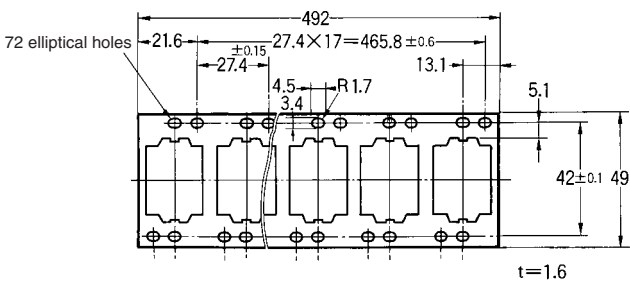

## Tracks and Accessories

### Supporting Tracks

PFP-50N/PFP-100N

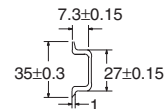
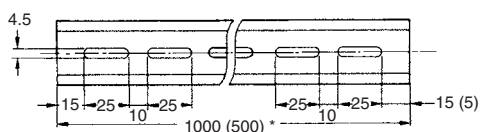
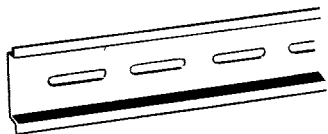

**Note:** The figure in the parentheses is for PFP-50N.

PFP-100N2

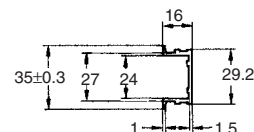
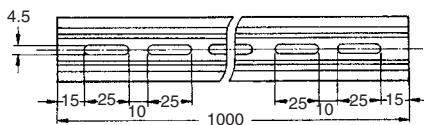
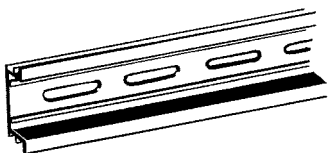

### End Plate

PFP-M

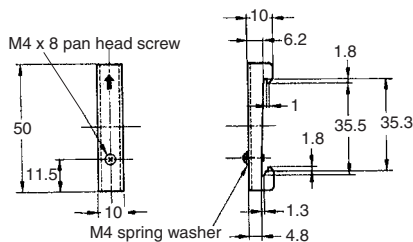
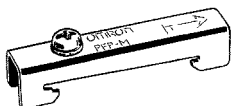

### Spacer

PFP-S

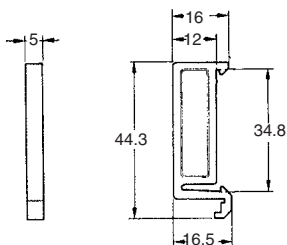
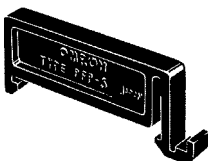

ALL DIMENSIONS SHOWN ARE IN MILLIMETERS.  
To convert millimeters into inches, multiply by 0.03937. To convert grams into ounces, multiply by 0.03527.

# General-purpose Relay MY

## An Improved Miniature Power Relay with Many Models for Sequence Control and Power Applications

- A wide range of relay variations including ones with operation indicators, built-in diodes, etc.
- Arc barrier standard on 3- and 4-pole Relays.
- Dielectric strength: 2,000 VAC.

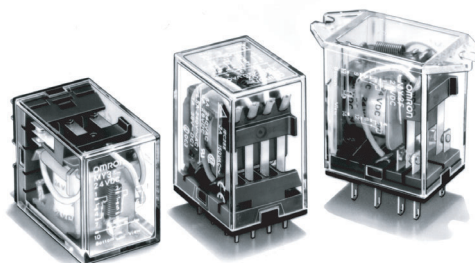

## Ordering Information

### List of Models

Type	Contact form	Plug-in socket/solder terminals		PCB terminals	Upper-mounting/solder terminals
			With indicator		
Standard	DPDT	---	---	MY2-02	MY2F
	3PDT	MY3	MY3N	MY3-02	MY3F
	4PDT	---	---	MY4-02	MY4F
	4PDT (bifurcated)	---	---	MY4Z-02	MY4ZF
With built-in diode (DC only)	3PDT	MY3-D	MY3N-D2	---	---

Note: When ordering, add the rated coil voltage to the model number. Rated coil voltages are given in the coil ratings table.

Example: MY3, 6 VAC  
 Rated coil voltage

### Accessories (Order Separately)

#### Sockets

Poles	Front-mounting Socket (DIN-track/screw mounting)	Back-mounting Socket				
		Solder terminals		Wire-wrap terminals		PCB terminals
		W/ clip	W/o clip	W/ clip	W/o clip	
3	PYF11A	PY11	PY11-Y1	PY11QN	PY11QN-Y1	PY11-02

- Note: 1. Equipped with operation check terminal.  
 2. The PYF08A(-E), PYF11A, and PYF14A(-E) have been approved as individual Sockets by UL 508 and CSA C22.2.

#### Mounting Plates for Sockets

Socket model	For 1 Socket	For 18 Sockets	For 36 Sockets
PY11, PY11QN(2)	PYP-1	PYP-18	PYP-36

Note: PYP-18 and PYP-36 can be cut into any desired length in accordance with the number of Sockets.

## Socket Hold-down Clip Pairing

Relay type	Poles	Front-connecting Sockets (track-/screw-mounted)		Back-connecting Sockets			
				Solder/wire-wrap terminals		PCB terminals	
		Socket	Clip	Socket	Clip	Socket	Clip
Standard, operation indicator, built-in diode	3	PYF11A	PYC-A1	PY11(QN)	PYC-P	PY11-02	PYC-P

## Specifications

### ■ Coil Ratings

	Rated voltage	Rated current		Coil resistance	Coil inductance (reference value)		Must operate voltage	Must release voltage	Max. voltage	Power consum. (Approx.)
		50 Hz	60 Hz		Arm. OFF	Arm. ON				
AC	6 V	214.1 mA	183 mA	12.2 Ω	0.04 H	0.08 H	80% max.	30% min.	110%	1.0 to 1.2 VA (60 Hz)
	12 V	106.5 mA	91 mA	46 Ω	0.17 H	0.33 H				
	24 V	53.8 mA	46 mA	180 Ω	0.69 H	1.30 H				
	50 V	25.7 mA	22 mA	788 Ω	3.22 H	5.66 H				
	100/110 V	11.7/12.9 mA	10/11 mA	3,750 Ω	14.54 H	24.6 H				
	110/120 V	9.9/10.8 mA	8.4/9.2 mA	4,430 Ω	19.20 H	32.1 H				
	200/220 V	6.2/6.8 mA	5.3/5.8 mA	12,950 Ω	54.75 H	94.07 H				
	220/240 V	4.8/5.3 mA	4.2/4.6 mA	18,790 Ω	83.50 H	136.40 H				
DC	6 V	150 mA		40 Ω	0.17 H	0.33 H	10% min.		0.9 W	
	12 V	75 mA		160 Ω	0.73 H	1.37 H				
	24 V	36.9 mA		650 Ω	3.20 H	5.72 H				
	48 V	18.5 mA		2,600 Ω	10.60 H	21.00 H				
	100/110 V	9.1/10 mA		11,000 Ω	45.60 H	86.20 H				

- Note:**
1. The rated current and coil resistance are measured at a coil temperature of 23°C with tolerances of +15%/–20% for rated currents and ±15% for DC coil resistance.
  2. Performance characteristic data are measured at a coil temperatures of 23°C.
  3. AC coil resistance and impedance are provided as reference values (at 60 Hz).
  4. Power consumption drop was measured for the above data. When driving transistors, check leakage current and connect a bleeder resistor if required.

### ■ Contact Ratings

Item	Double- or three-pole		Four-pole	
	Resistive load ( $\cos\phi = 1$ )	Inductive load ( $\cos\phi=0.4$ , L/R=7 ms)	Resistive load ( $\cos\phi = 1$ )	Inductive load ( $\cos\phi=0.4$ , L/R=7 ms)
<b>Rated load</b>	5 A, 220 VAC 5 A, 24 VDC	2 A, 220 VAC 2 A, 24 VDC	3 A, 220 VAC 3 A, 24 VDC	0.8 A, 220 VAC) 1.5 A, 24 VDC
<b>Carry current</b>	5 A		3 A	
<b>Max. switching voltage</b>	250 VAC 125 VDC		250 VAC 125 VDC	
<b>Max. switching current</b>	5 A	5 A	3 A	3 A
<b>Max. switching power</b>	1,100 VA 120 W	440 VA 48 W	660 VA 72 W	176 VA 36 W
<b>Failure rate (reference value)*</b>	Standard type: 100 mA, 5 VDC		Standard types: 1 mA, 1 VDC Bifurcated type: 100 μA, 1 VDC	

\*Note: P level:  $\lambda_{60} = 0.1 \times 10^{-6}$ /operation, reference value

## ■ Characteristics

Item	All Relays
Contact resistance	50 mΩ max.
Operate time	20 ms max.
Release time	20 ms max.
Max. operating frequency	Mechanical: 18,000 operations/hr Electrical: 1,800 operations/hr (under rated load)
Insulation resistance	1,000 MΩ min. (at 500 VDC)
Dielectric strength	2,000 VAC, 50/60 Hz for 1 min (1,000 VAC between contacts of same polarity)
Vibration resistance	Destruction: 10 to 55 to 10 Hz, 0.5 mm single amplitude (1.0 mm double amplitude) Malfunction: 10 to 55 to 10 Hz, 0.5 mm single amplitude (1.0 mm double amplitude)
Shock resistance	Destruction: 1,000 m/s <sup>2</sup> Malfunction: 200 m/s <sup>2</sup>
Endurance	See following table.
Ambient temperature*	Operating: (standard): -55°C to 70°C (with no icing) Built-in LED indicator; built-in diode: -55°C to 60°C (with no icing)
Ambient humidity	Operating: 5% to 85%
Weight	Approx. 35 g

Note: The values given above are initial values.

## Endurance Characteristics

Contact form	Mechanical life (at 18,000 operations/hr)	Electrical life (at 1,800 operations/hr under rated load)
Normal	AC: 50,000,000 operations min. DC: 100,000,000 operations min.	2-,3-pole: 500,000 operations min. 4-pole: 200,000 operations min.
With bifurcated contacts	4-pole: 20,000,000 operations min.	4-pole: 100,000 operations min.

Note: See following tables for real load life expectancies.

## ■ Endurance Under Real Loads

### MY2

Rated voltage	Load type	Conditions	Operating frequency	Electrical life
100 VAC	AC motor	50 W, 100 VAC single-phase with 2.8-A inrush current, 0.4-A carry current	ON for 2 s, OFF for 30 s	100,000 operations
		50 W, 100 VAC single-phase with 1.6-A inrush current, 1-A carry current	ON for 1 s, OFF for 30 s	300,000 operations
	AC solenoid	24 W with 1-A carry current	ON for 1.5 s, OFF for 1.5 s	4,000,000 operations

### MY4

Rated voltage	Load type	Conditions	Operating frequency	Electrical life
100 VAC	AC solenoid	50 VA with 2-A inrush current, 0.7-A carry current	ON for 1 s, OFF for 3 s	25,000 operations
	DC magnetic switch	25 W with L/R = 40 ms, 0.2-A carry current		
	AC magnetic switch	35 VA with 1.5-A inrush current, 0.35-A carry current		500,000 operations
24 VDC	DC solenoid	40 W with L/R = 10 ms, 1.6-A carry current	ON for 0.5 s, OFF for 1.5 s	5,000,000 operations
		30 W with L/R = 10 ms with 0.34-A carry current	ON for 0.5 s, OFF for 1.5 s	6,000,000 operations

## ■ Approved Standards

Some MY Relays are available in models meeting various safety standards. When ordering, you must specify the desired standards. Refer to *Ordering Information* for specific models. Note that the rating recognized by the various standards sometimes vary from the ratings of the individual Relays.

### UL 508 Recognitions (File No. 41515)

No. of poles	Coil ratings	Contact ratings	Operations
2, 3	6 to 240 VAC 6 to 125 VDC	5 A, 28 VDC (Resistive) 5 A, 240 VAC (General use)	6 x 10 <sup>3</sup>
4		5 A, 240 VAC (General use) (Same polarity) 5 A, 28 VDC (Resistive) (Same polarity)	

### CSA C22.2 No. 14 Listings (File No. LR31928)

No. of poles	Coil ratings	Contact ratings	Operations
2, 3	6 to 240 VAC 6 to 125 VDC	5 A, 28 VDC (Resistive) 5 A, 240 VAC (General use)	6 x 10 <sup>3</sup>
4		5 A, 240 VAC (General use) (Same polarity) 5 A, 28 VDC (Resistive) (Same polarity)	

### SEV Listings (File No. 99.5 50902.01)

No. of poles	Coil ratings	Contact ratings
2, 3, 4	6 to 240 VAC 6 to 125 VDC	5 A, 240 VAC1 5 A, 28 VDC1

### LR (No. 563KOB-204524)

No. of poles	Coil ratings	Contact ratings
2	6 to 240 VAC 6 to 120 VDC	2 A, 200 VAC (General use) 2 A, 30 VDC (General use)
4		0.8 A, 200 VAC (General use) 1.5 A, 115 VAC (General use) 1.5 A, 30 VDC (General use)

## Engineering Data

### Maximum Switching Power

#### MY2-02, MY2F, MY3 Series

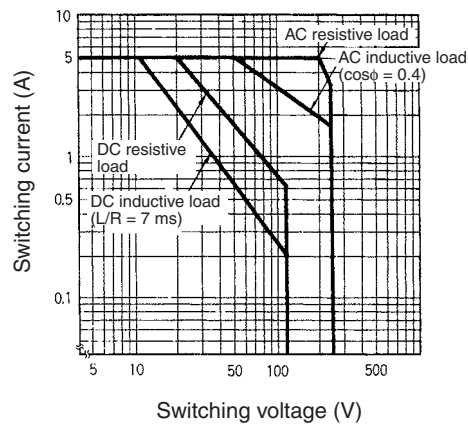

#### MY4(Z)-02, MY4F, MY4ZF

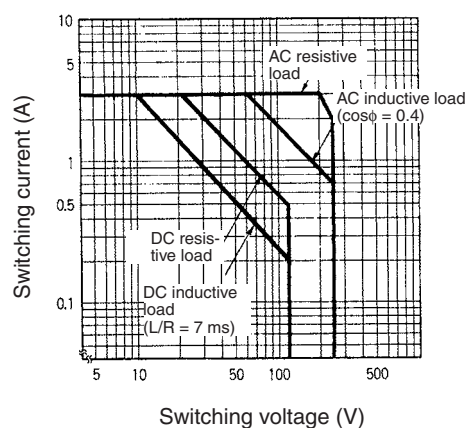

**Endurance**

**MY2-02, MY2F, MY3 Series (Resistive Loads)**

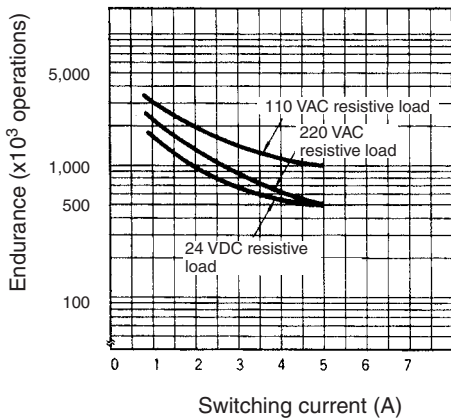

**MY2-02, MY2F, MY3 Series (Inductive Loads)**

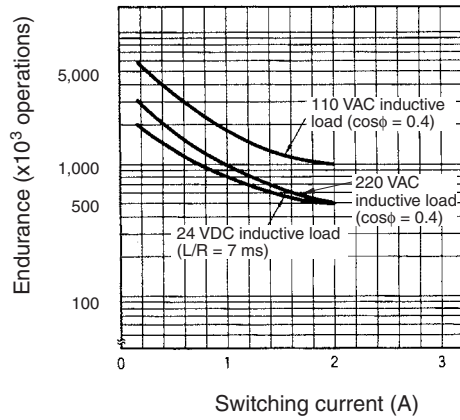

**MY4-02, MY4F (Resistive Loads)**

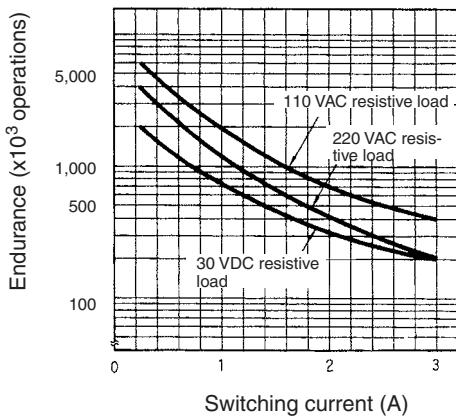

**MY4-02, MY4F (Inductive Loads)**

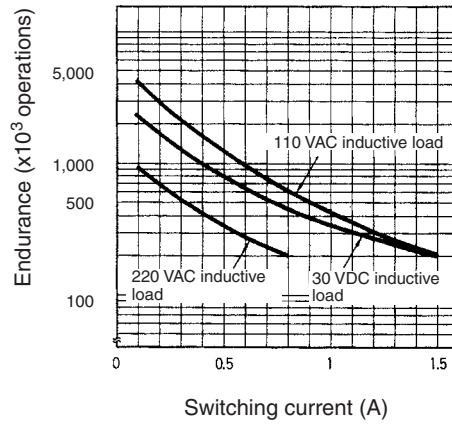

**MY4Z-02, MY4ZF (Resistive Loads)**

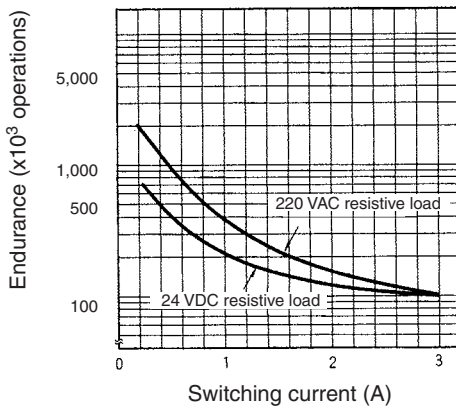

**MY4Z-02, MY4ZF (Inductive Loads)**

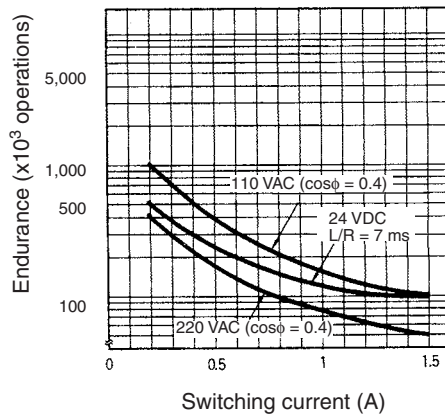



## Upper-mounting Relays

MY□F

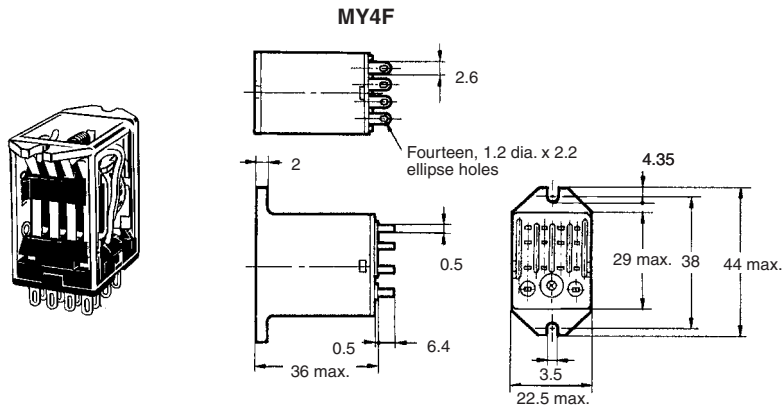

### Mounting Holes

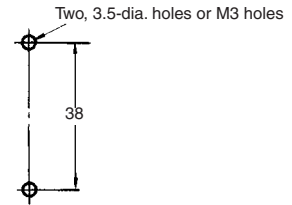

- Note:**
1. The above dimensions also apply to the DPDT, and 3PDT Relays.
  2. The internal connections of the above Relays are as same as these of MY□ Relays.

## Mounting Height with Socket

### DIN Track/Surface-mounting Socket

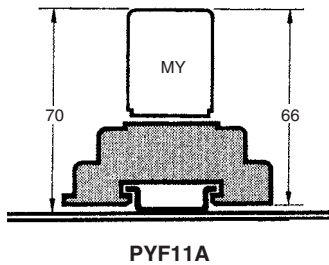

### Back-mounting Socket

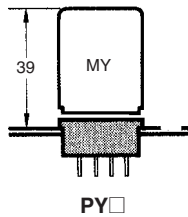

**Note:** The PYF( )A can be track-mounted or screw-mounted.

## Sockets

PYF11A

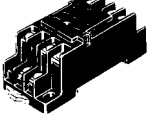

PY11

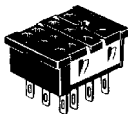

PY11-02

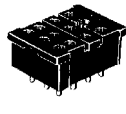

## Mounting Plates for Backconnecting Sockets

PYP-1

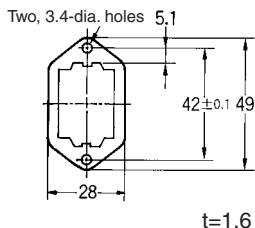

PYP-18

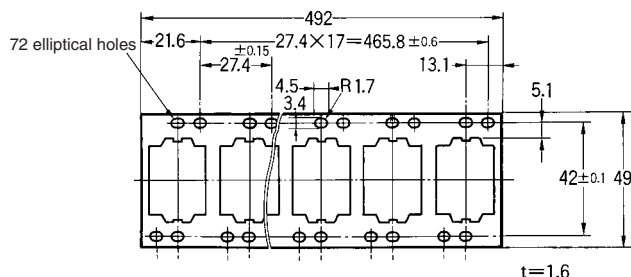

PYP-36

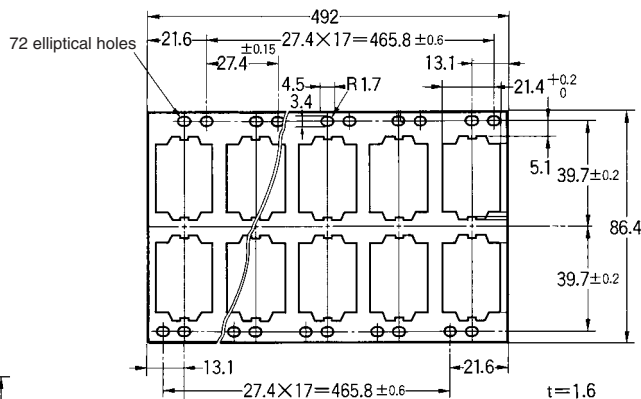

## Hold-down Clips

Hold-down clips are used to hold Relays to Sockets and prevent them from coming loose due to vibration or shock.

Connection to Socket		Connection to mounting plate
PYC-A1	PYC-P	PYC-S

## ■ Safety Standards for Sockets

Item	Standards	File No.
PYF11A	UL508	E87929
	CSA22.2	LR31928

## Precautions

Refer to page 11 for general precautions.

### ■ Connections

Do not reverse polarity when connecting DC-operated Relays with built-in diodes or indicators or high-sensitivity DC-operated Relays.

### ■ Mounting

- Whenever possible, mount Relays so that it is not subject to vibration or shock in the same direction as that of contact movement.

ALL DIMENSIONS SHOWN ARE IN MILLIMETERS.  
To convert millimeters into inches, multiply by 0.03937. To convert grams into ounces, multiply by 0.03527.