

OMRON

# 1/32-DIN Preset Counter/Timer



**H8GN**  
Preset Counter/Timer

# FIRST in the world:

**Preset Counter & Timer combined in one body in "G" format FIRST**  
**Double display: PV & SV, in "G" format FIRST**  
**Serial communication in "G" format FIRST**

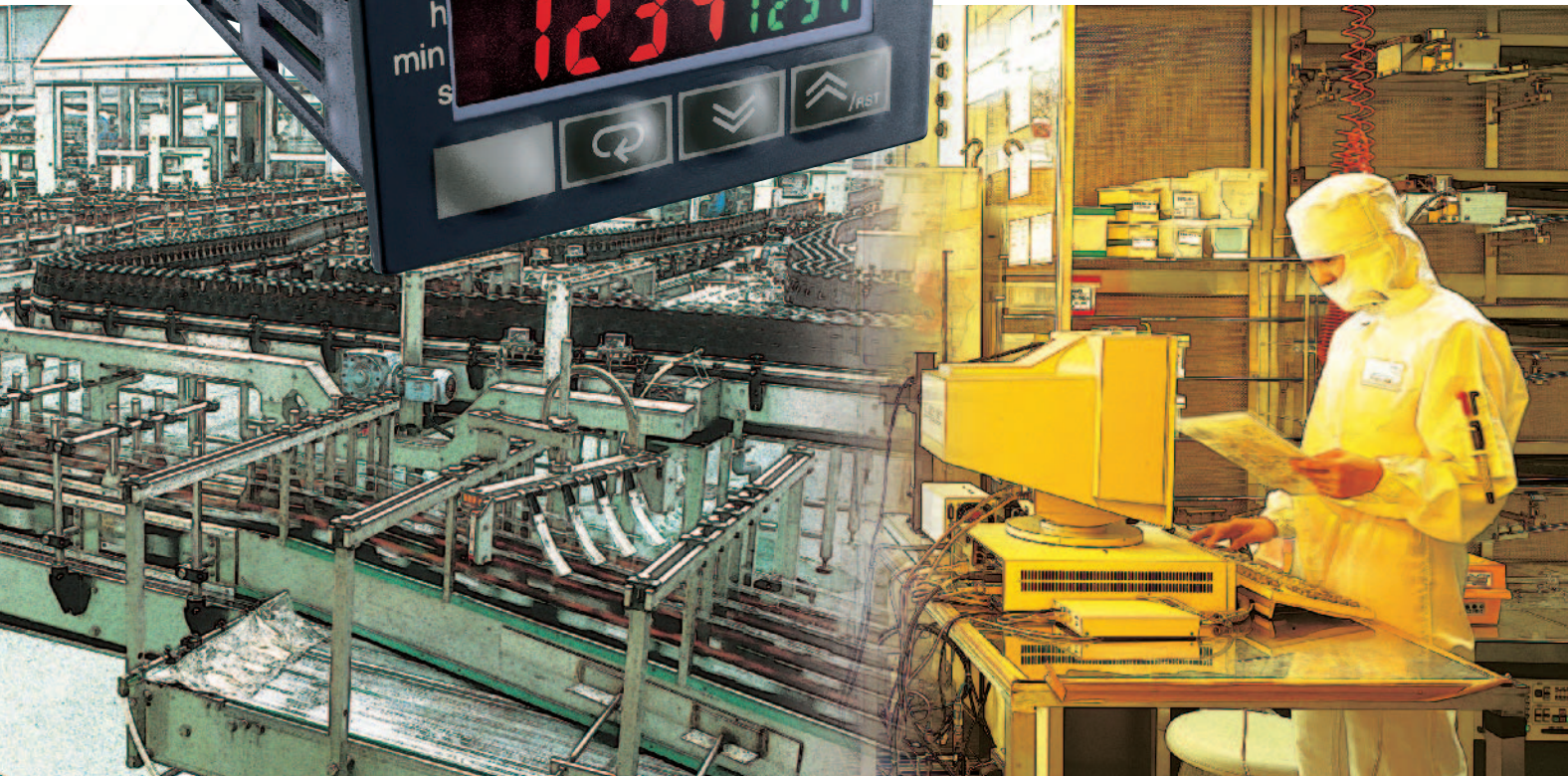

The H8GN, with the world's smallest dimensions of 48 x 24 mm (1/32-DIN size or "G" format), facilitates easier system design and installation and helps enhance performance for downsizing or systemization. An intuitive operability reduces setup time. The H8GN helps pursue a higher productivity on shop floor.

**G-FORMAT** Preset Counter/Timer



## Save Effort

Save the time required to setup for a process.  
 More efficient management through a system integration.  
 Simplified operation.

## Save Space

Help downsizing of control panel, both in footprint and volume.  
 Greater space utilization is also achieved by its versatility.

## Save Energy

Reduced power consumption using backlit negative transmissive LCD.  
 Environment-friendly design without batteries.  
 Fine adjustable control.

### SV-Bank Function

Enables presetting up to four set values and changing one to another with a simple operation on a front panel key. This feature helps reduce the setup time required to change between processes.

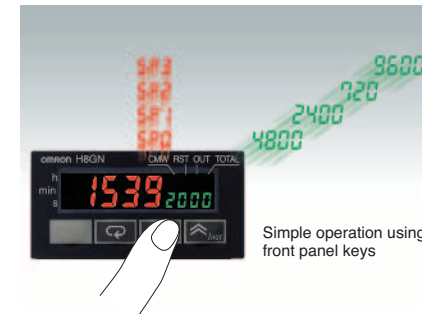

### World's Smallest Size for Downsizing of Control Panels

A compact and short body of DIN 48 x 24 x 83 mm



### LED-like LCD Double Display. Programs saved without using batteries

Both PV and SV can be viewed on a large, high-visibility negative-transmissive LCD.



## FIRST in the world:

Preset Counter & Timer combined in one body in "G" format FIRST  
 Double display: PV & SV, in "G" format FIRST  
 Serial communication in "G" format FIRST



### Communications Function Facilitating Data Management

The H8GN Series includes a model with serial communications. It can be connected up to 32 devices or computers.

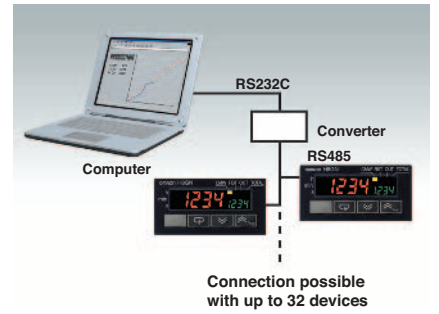

### Triple in one - features total and preset counter functions as well as timer

Switching between preset counter (4 digits) and timer (4 digits) possible. While using the preset counter, it is possible to switch the display to monitor the totalizing count value (8 digits). This feature eliminates the need for more than one device to enable saving space.

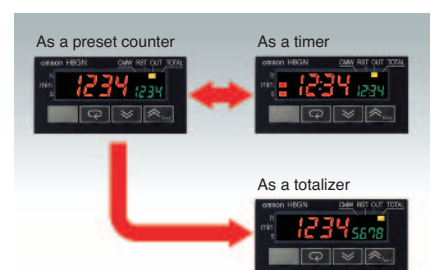

### Equipped with ON/OFF-duty Adjustable Flicker Mode

ON/OFF duty adjustable flicker mode that can be used to perform cyclic control is available for timer operation. This feature allows fine adjustment of control output and saves energy.

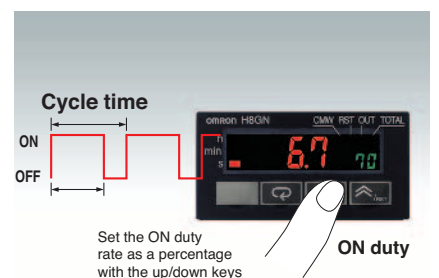

### World's Smallest Compact Preset Counter/Timer

#### 1/32-mm DIN with Communications

- Only 48 x 24 x 83 mm (W x H x D)
- Switch between 4-digit preset counter and 4-digit timer operation.
- While using the preset counter, it is possible to switch the display to monitor the totalizing count value (8 digits).
- Built-in prescaling for counter operation.
- ON/OFF-duty adjustable flicker mode that can be used to perform cyclic control is available for timer operation.
- Four preset values that can be changed by the front panel key (SV-bank).
- Finger protection terminal block to meet VDE0106/P100.
- Panel surface compatible with NEMA4X/IP66.
- Conforms to UL, CSA, and IEC safety standards as well as CE Marking.
- Six-language instruction manual provided.



### Ordering Information

Supply voltage	Output	Communications	
		No communications	RS-485
24 VDC	Contact output (SPDT)	H8GN-AD	H8GN-AD-FLK

#### Model Number Legend:

H8GN-AD-□  
1 2

1. **Supply Voltage**  
D: 24 VDC

2. **Communications Output Type**  
None: Communications not supported  
FLK: RS-485

# Specifications

## ■ Ratings

<b>Rated supply voltage</b>		24 VDC
<b>Operating voltage range</b>		85% to 110% of rated supply voltage
<b>Power consumption</b>		1.5 W max. (for max. DC load) (Inrush current: 15 A max.)
<b>Mounting method</b>		Flush mounting
<b>External connections</b>		Screw terminals (M3 screws)
<b>Terminal screw tightening torque</b>		0.5 N·m max.
<b>Attachment</b>		Waterproof packing, flush mounting bracket
<b>Display</b>		7-segment, negative transmissive LCD; time display (h, min, s); CMW, OUT, RST, TOTAL Present value (red, 7-mm-high characters); Set value (green, 3.4-mm-high characters)
<b>Digits</b>		PV: 4 digits SV: 4 digits When total count value is displayed: 8 digits (Zeros suppressed)
<b>Memory backup</b>		EEPROM (non-volatile memory) (number of writes: 100,000 times)
<b>Counter</b>	<b>Maximum counting speed</b>	30 Hz or 5 kHz (See note.)
	<b>Counting range</b>	–999 to 9,999
	<b>Input modes</b>	Increment, decrement, individual, quadrature inputs
	<b>Output modes</b>	N, F, C, or K
<b>Timer</b>	<b>Time ranges</b>	0.000 to 9.999 s, 0.00 to 99.99 s, 0.0 to 999.9 s, 0 to 9999 s, 0 min 00 s to 99 min 59 s, 0.0 to 999.9 min, 0 h 00 min to 99 h 59 min, 0.0 h to 999.9 h, 0 h to 9999 h
	<b>Timer modes</b>	Elapsed time (Up), remaining time (Down)
	<b>Output modes</b>	A, B, D, E, F, or Z
<b>Inputs</b>	<b>Input signals</b>	For Counter: CP1, CP2, and reset For Timer: Start, gate, and reset
	<b>Input method</b>	No-voltage input (contact short-circuit and open input) Short-circuit (ON) impedance: 1 K $\Omega$ max. (Approx. 2 mA runoff current at 0 $\Omega$ ) Short-circuit (ON) residual voltage: 2 VDC max. Open (OFF) impedance: 100 k $\Omega$ min. Applied voltage: 30 VDC max.
	<b>Start, reset, gate</b>	Minimum input signal width: 1 or 20 ms (selectable)
	<b>Power reset</b>	Minimum power-opening time: 0.5 s
<b>Control output</b>		SPDT contact output: 3 A at 250 VAC/30 VDC, resistive load ( $\cos \phi = 1$ )
<b>Minimum applied load</b>		10 mA at 5 VDC (failure level: P, reference value)
<b>Reset system</b>		External, manual, and power supply resets (for timer in A, B, D, E, or Z modes)
<b>Sensor waiting time</b>		260 ms max. (Inputs cannot be received during sensor wait time if control outputs are turned OFF.)

**Note:** The figures given for maximum counting speed are for incrementing or decrementing operation with a prescale value of  $\times 1$ . If prescaling is used and 5 kHz is set, the maximum counting speed will be reduced to about half. The maximum counting speed will also be reduced to about half when the up/down mode is selected.

## ■ Characteristics

<b>Timer function</b>	<b>Accuracy of operating time and setting error (including temperature and voltage effects)</b>	Signal start: $\pm 0.03\% \pm 30$ ms max. Power-ON start: $\pm 0.03\% \pm 50$ ms max.
<b>Insulation resistance</b>		100 M $\Omega$ min. (at 500 VDC)
<b>Dielectric strength</b>		1,500 VAC, 50/60 Hz for 1 min between output terminals and non-current-carrying metal parts 510 VAC, 50/60 Hz for 1 min between current-carrying terminals (except output terminals) and non-current-carrying metal parts 1,500 VAC, 50/60 Hz for 1 min between output terminals and current-carrying terminals (except output terminals) 500 VAC, 50/60 Hz for 1 min between communications terminals and current-carrying terminals (except output terminals) 1,000 VAC, 50/60 Hz for 1 min between contacts not located next to each other
<b>Noise immunity</b>		Square-wave noise by noise simulator; $\pm 480$ V (between power terminals), $\pm 600$ V (between input terminals)
<b>Static immunity</b>		$\pm 8$ kV (malfunction), $\pm 15$ kV (destruction)
<b>Vibration resistance</b>	<b>Malfunction</b>	10 to 55 Hz with 0.35-mm single amplitude each in three directions for 10 min
	<b>Destruction</b>	10 to 55 Hz with 0.75-mm single amplitude each in three directions for 2 h
<b>Shock resistance</b>	<b>Malfunction</b>	100 m/s <sup>2</sup> , 3 times each in six directions
	<b>Destruction</b>	300 m/s <sup>2</sup> , 3 times each in six directions
<b>Life expectancy</b>	<b>Mechanical</b>	10 million operations
	<b>Electrical</b>	100,000 operations min. (3 A at 250 VAC, resistive load)
<b>Ambient temperature</b>	<b>Operating</b>	-10°C to 55°C (with no icing or condensation)
	<b>Storage</b>	-25°C to 65°C (with no icing or condensation)
<b>Ambient humidity</b>		25% to 85%
<b>EMC</b>		(EMI): Emission Enclosure: EN61326 Class A EN61326 (EMS): Immunity ESD: EN61000-4-2: 4 kV contact discharge (level 2) 8 kV air discharge (level 3) Immunity RF-interference: EN61000-4-3: 10 V/m (Amplitude-modulated, 80 MHz to 1 GHz) (level 3); 10 V/m (Pulse-modulated, 900 MHz $\pm$ 5 MHz) (level 3)  Immunity Conducted Disturbance: EN61000-4-6: 3 V (0.15 to 80 MHz) (level 2) Immunity Burst: EN61000-4-4: 2 kV power-line (level 3); 1 kV I/O signal-line (level 4); 1 kV communications-line (level 3)  Immunity Surge: EN61000-4-5: 1 kV between lines (power and output lines) (level 3); 2 kV between grounds (power and output lines) (level 3)
<b>Approved standards</b>		UL508, CSA C22.2 No.14 Conforms to EN61010-1/IEC61010-1 (Pollution degree 2/overvoltage category II) Conforms to VDE0106/P 100 (Finger Protection)
<b>Case color</b>		Rear section: Gray smoke; Front section: N1.5 (black)
<b>Enclosure ratings</b>		Panel surface: IP66 and NEMA Type 4X (indoors) Rear case: IP20 Terminal block: IP20
<b>Weight</b>		Approx. 80 g

## ■ Communications Specifications

<b>Transmission path connections</b>	Multidrop
<b>Communications method</b>	RS-485 (two-wire, half duplex)
<b>Synchronization method</b>	Start-stop synchronization
<b>Baud rate (See note.)</b>	1,200/2,400/4,800/9,600 bit/s
<b>Transmission code</b>	ASCII
<b>Data bit length (See note.)</b>	7 or 8 bits
<b>Stop bit length (See note.)</b>	1 or 2 bits
<b>Error detection (See note.)</b>	Vertical parity (none, even, or odd) (See note.) Block check character (BCC)
<b>Flow control</b>	Not supported.
<b>Interface</b>	RS-485
<b>Retry function</b>	Not supported.
<b>Communications buffer</b>	40 bytes
<b>Reading and writing from H8GN</b>	Reading present value and totalizing count value; reading/writing preset and set values; switching between SV-banks; switching between communications write-enabled/write-prohibited; reading/writing other initial and advanced function setting parameters

**Note:** The baud rate, data bit length, stop bit length, and vertical parity can be individually set using the communications setting level.

# Nomenclature

### No. 1 Display

Displays the present value or parameter type. When totalizing count is displayed, the leftmost 4 digits of the 8-digit totalizing count will be displayed. (Zeros suppressed)

### Operation display 2

Indicator	Meaning
CMW	Lit when communications writing is enabled.
RST	Lit during reset using reset input or Reset Key.
OUT	Lit when control output is ON.
TOTAL	Lit when totalizing count value is displayed.

### Operation display 1

Displays the time unit when the timer function has been selected.

#### Example

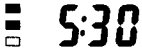
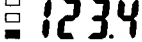
5 h 30 min   
 123.4 s 

Flashes while timer is on 0.0 min, 0 h 00 min, 0.0 h, or 0 h.

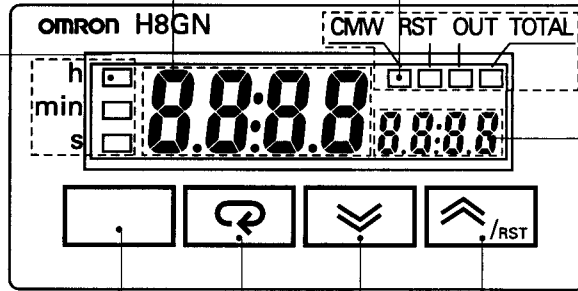

### No. 2 Display

Displays set value or set value of the parameter. Displays the rightmost 4 digits of the count value (8 digits) when the H8GN is used as a totalizing counter. (Zeros suppressed)

### Level Key

Press this key to select the setup level. The setup level is selected in order "operation level" ↔ "adjustment level", "initial setting level" ↔ "communications setting level".

### Mode Key

Press this key to select parameters within each level.

### Down Key

Each press of this key decreases values displayed on the No. 2 display. Hold down this key continuously to decrease values quickly. Also returns setting items.

### Up/Reset Key

Each press of this key increases values displayed on the No. 2 display. Hold down this key continuously to increase values quickly. Also advances setting items.

### Reset Function

To reset the present value, press this key while the present value is displayed. If this key is pressed while the totalizing count value is displayed, the totalizing count value and the present value will be reset.

# Operation

## ■ Block Diagram

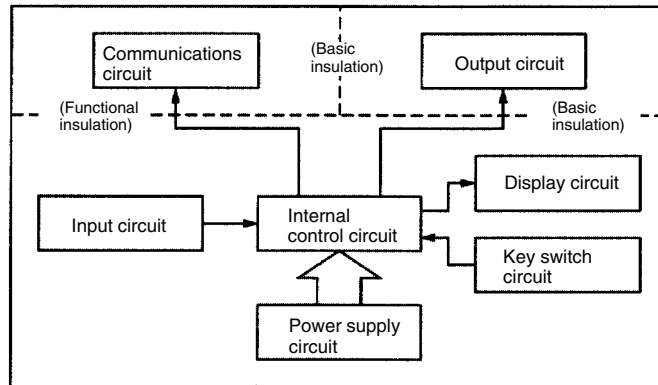

## ■ I/O Functions

<b>Inputs</b>	<b>Counter inputs</b>	<b>CP1/CP2</b>	<ul style="list-style-type: none"> <li>Receive count signals.</li> <li>Receive increment, decrement, individual, and quadrature inputs.</li> <li>In increment mode and decrement mode, CP1 is used for the count input and CP2 is used for count prohibit input.</li> </ul>
		<b>Reset</b>	<ul style="list-style-type: none"> <li>Resets the present value. (Totalizing count value is not reset.) (In increment mode or increment/decrement mode, the present value returns to 0; in Decrement Mode the present value returns to the set value.)</li> <li>The count input is not received during resetting.</li> <li>The RST indicator is lit during resetting.</li> </ul>
	<b>Timer inputs</b>	<b>Start</b>	<ul style="list-style-type: none"> <li>Starts timing.</li> </ul>
		<b>Reset</b>	<ul style="list-style-type: none"> <li>Resets the timer. (In elapsed time mode the time returns to 0; in remaining time mode, the time returns to the set value.)</li> <li>During resetting, timing stops and the control output turns OFF.</li> <li>The RST indicator is lit during resetting.</li> </ul>
		<b>Gate</b>	<ul style="list-style-type: none"> <li>Prohibits timing operation.</li> </ul>
	<b>Outputs</b>	<b>OUT</b>	<ul style="list-style-type: none"> <li>Output made according to the output mode setting when the set value is reached.</li> </ul>

# Initial Setup

The and Keys are used to switch between setup menus, and the amount of time that you hold the keys down for determines which setup menu you move to. This section describes two typical examples.

**Note:** In the following sections, "PV" is used to indicate a present value and "SV" to indicate a set value.

## 1. Using the H8GN as a Counter

### Typical Application Examples • Setup Procedure

**1. Changing Set Values**

Set value and selections in each display can be changed by pressing the and Keys.

**2. Displays**

No. 1 display No. 2 display

### Typical Application

Input mode	Individual input
Output mode	F (overcount)
Counting speed	30 Hz
Input signal width	20 ms
Decimal point	None
Prescale	None

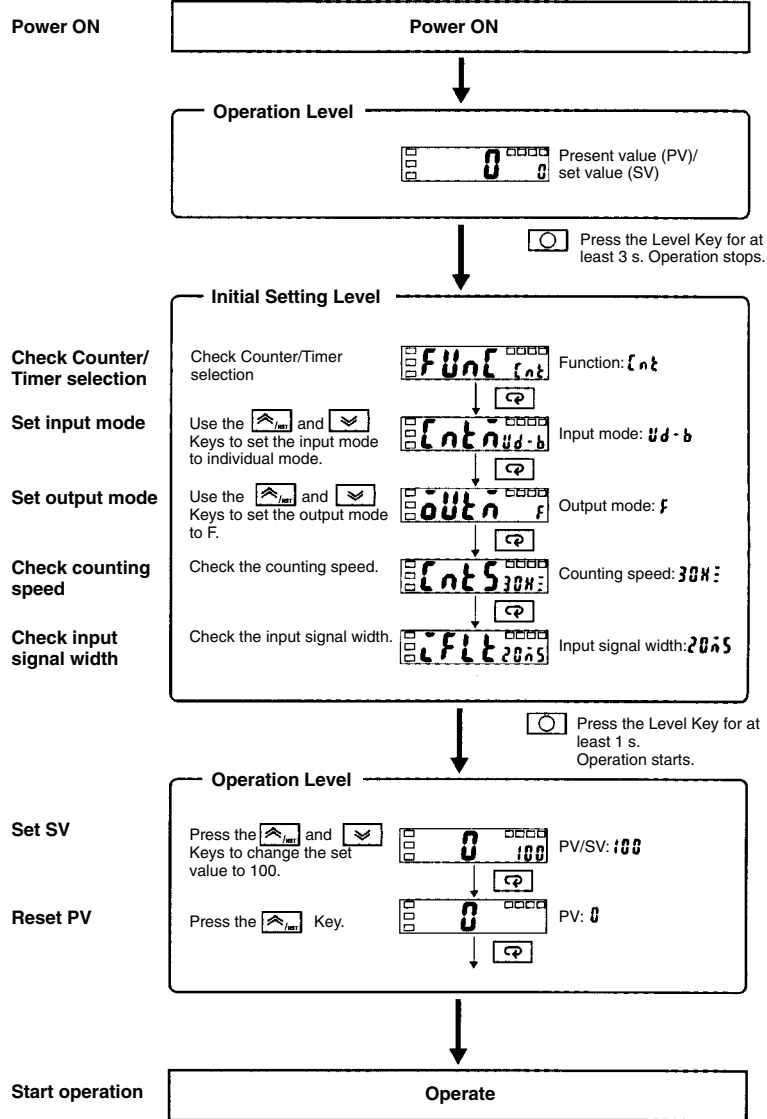

### • Confirming Set Values

Set values are effective two seconds after key operation is stopped or when the or Key is pressed.

## 2. Using the H8GN as a Timer

### Typical Application Examples

#### 1. Changing Set Values

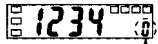

Set value and selections in each display can be changed by pressing the and Keys.

#### 2. Display

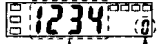

No. 1 Display No. 2 Display

### Typical Application Examples

Time range	0.0 to 999.9 s
Timer mode	DOWN (remaining time)
Output mode	A mode
Output time	Hold
Input signal width	20 ms

### • Setup Procedure

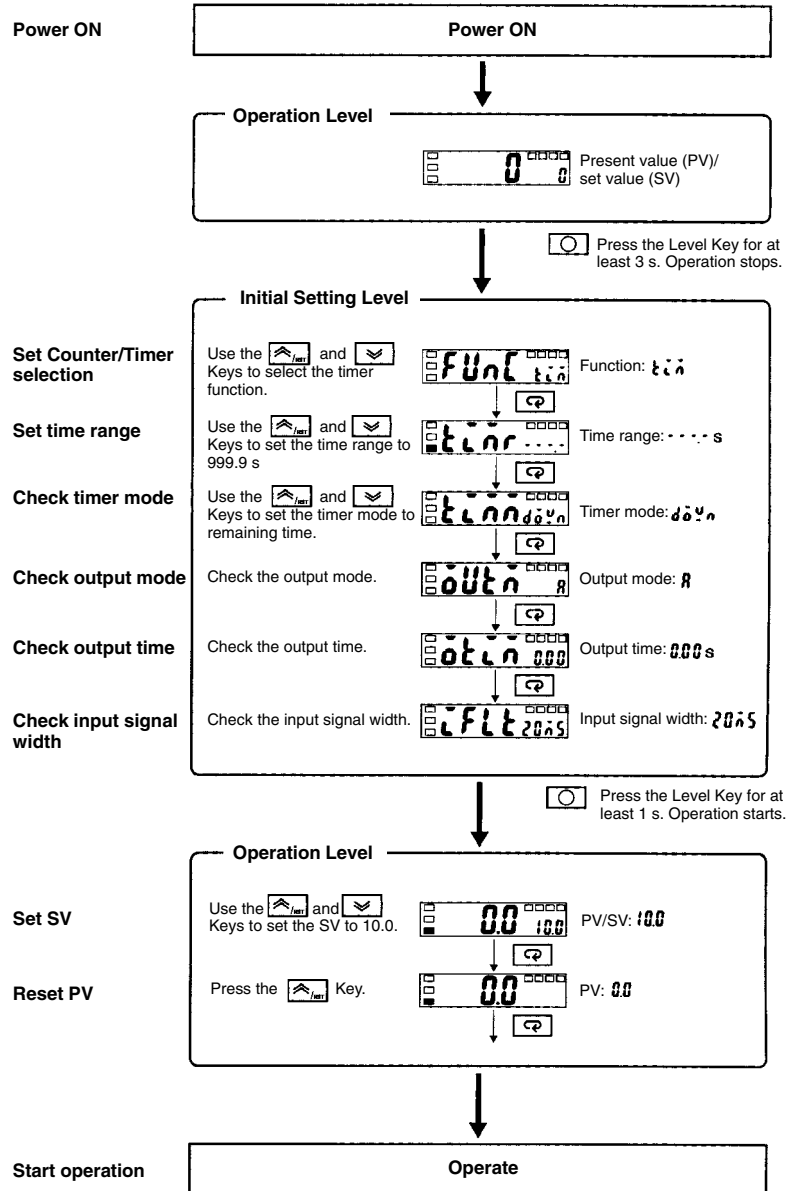

### • Confirming Set Values

Set values are effective two seconds after key operation is stopped or when the or Key is pressed.

# Setting Specifications after Turning ON Power

## ■ Outline of Operation Procedure

### Key Operation

In the following descriptions, all the parameters are introduced in the display sequence. Some parameters may not be displayed depending on the protection settings and operating conditions.

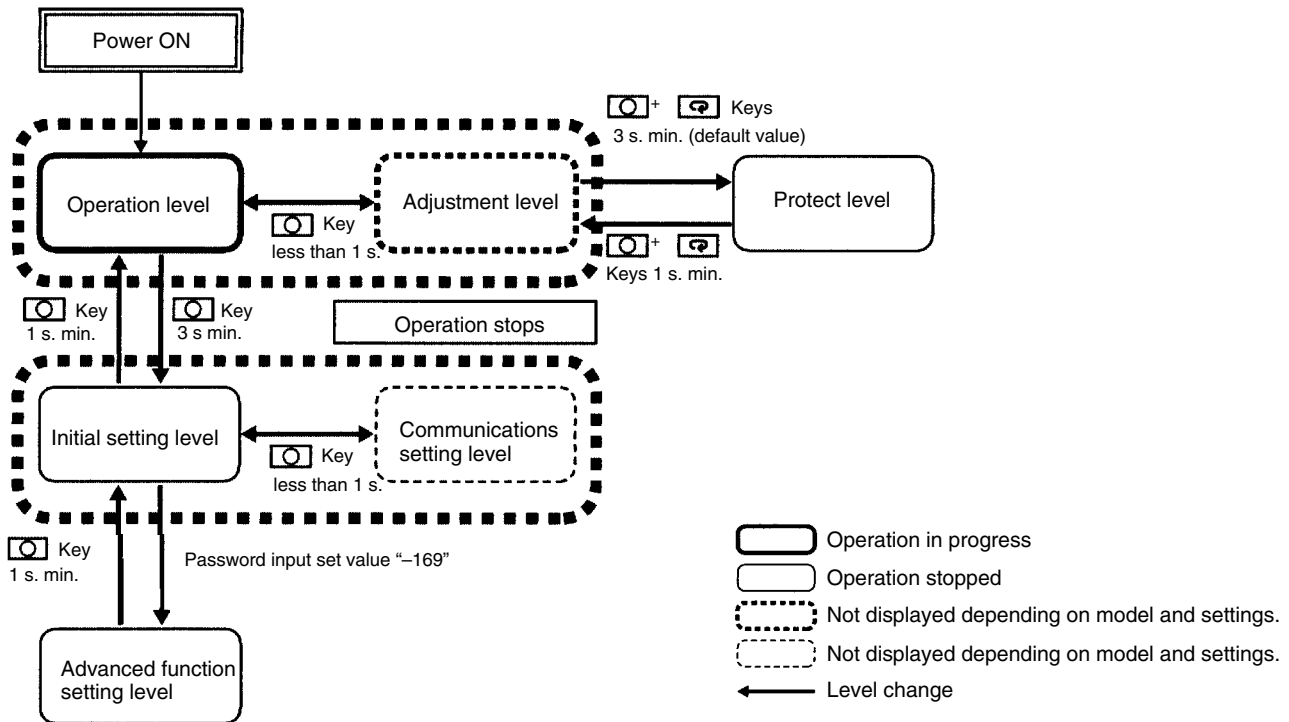

**Note:** Of these levels, the initial setting level, communications setting level, and advanced function setting level can be used only when operation has stopped. Control output is stopped when these three levels are selected. When switched back to the operation level from one of these levels, operation will start.

## ■ Description of Each Level

### Operation Level

- This level is displayed when you turn the power ON. You can move to the protect level, initial setting level, and adjustment level from this level.
- Normally, select this level during operation.
- During operation, the present value, set value, totalizing count value, and setting number of SV-bank can be monitored using the Key.

### Adjustment Level

- To select this level, press the Key once for less than one second.
- This level is for entering set value (SV 0 to 3) for operation. This level contains parameters for communications writing enable/disable, set value of SV-bank, and cycle time (timer Z mode).
- You can move to the top parameter of the operation level, protect level, or initial setting level from here.

### Initial Setting Level

- To select this level, press the Key for at least three seconds in the operation level or adjustment level.
- This level is for selecting the function, input mode, time range, timer mode, output mode, output time, counting speed, input signal width, decimal point position, prescale value, and rising/falling edge for input signal.

- You can move to the advanced function setting level or communications setting level from this initial setting level. To return to the operation level, press the Key for at least one second. To move to the communications setting level, press the key once for less than one second.

### Protect Level

- To select this level, simultaneously press the and Keys for at least three seconds (default value). This level is to prevent unwanted or accidental modification of parameters. Protected levels will not be displayed, and so the parameters in that level cannot be modified.

### Communications Setting Level

- To select this level, press the Key once for less than one second in the initial setting level. When the communications function is used, set the communications conditions in this level. Communicating with a personal computer (host computer) allows set values to be read and written.

### Advanced Function Setting Level

- To select this level, you must change the initial settings/communications protection setting in the protect level to "0" and then enter the password ("-169") in the initial setting level.
- This level is for initializing settings, enabling SV-bank and totalizing counter use, setting display auto-return time, and move-to-protect-level time.
- You can move to the initial setting level from this level.

■ Parameters

Operation Level

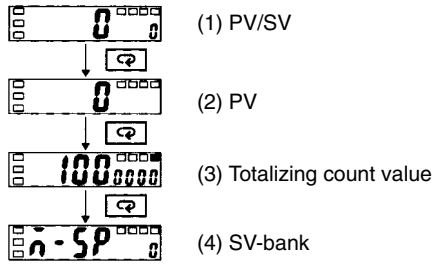

1. PV/SV

This display appears when the power is turned ON. No. 1 display shows the present value and No. 2 display shows the set value. The values displayed will be determined by the settings for Counter/Timer selection, time range, timer mode, and decimal point position made in the initial setting level.

Use the and Keys to change the settings.

2. PV

No. 1 display will show the present value and No. 2 display will remain blank. The values displayed will be determined by the settings for Counter/Timer selection, time range, timer mode, and decimal point position made in the initial setting level.

Press the Key to reset the present value.

3. Totalizing Count Value

The totalizing count value is displayed only if “totalizing counter used” in the advanced function setting level has been set to ON.

The leftmost four digits of the 8-digit totalizing count value will be shown in No. 1 display and the rightmost four digits will be shown in No. 2 display.

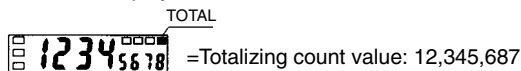

Press the Key to simultaneously reset the totalizing count value and the present value.



PV 0→1→2→3→0→1→2→0→1→2  
 Totalizing count value 0→1→2→3→3→4→5→0→1→2

Refer to **Input/Output Mode Settings** on page 21 for information on totalizing counter operation.

4. SV-bank (n-SP)

SV-bank is displayed only when “SV-bank used” in the advanced function setting level has been set to ON.

Select the SV-bank (SV 0 to 3). To use the SV-bank function, the four set values (SV 0 to 3) can be set beforehand in the adjustment level. The keys on the front of the Unit can then be used during operation to switch between the set values. For models with built-in communications, communications can be used to switch between the set values.

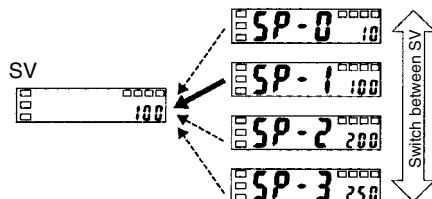

Adjustment Level

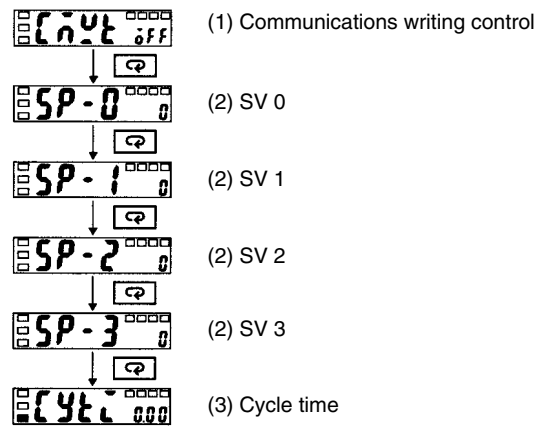

1. Communications Writing Control (E-n-UL)

**Communications writing control is displayed only for models with communications.**

Allows or prohibits communications to write data from a personal computer (host computer). Communications can be used to read data regardless of this setting.

2. SV 0 to 3 (SP-0, SP-1, SP-2, SP-3)

**SV 0 to 3 is displayed only when “SV-bank used” in the advanced function setting level has been set to ON.**

Used to set the set value when the SV-bank function is used. The operator can use the keys on the front to switch between the set values (SV 0 to 3). When the set value is changed in operation mode, the set value (SV 0 to 3) set in the adjustment level for SV-bank will also change.

3. Cycle Time (E-UL)

**Cycle time is displayed only when the “output mode for timer function” in the initial setting level has been set to “Z.”**

Sets the cycle time used for ON/OFF-duty adjustable flicker mode (Z). Cyclic control can be performed easily in ON/OFF-duty adjustable flicker mode by first setting the cycle time in the adjustment level and by using the set value in operation level to change the ON-duty ratio.

Controlling the flowrate by opening and closing the electromagnetic valve by pulse control.

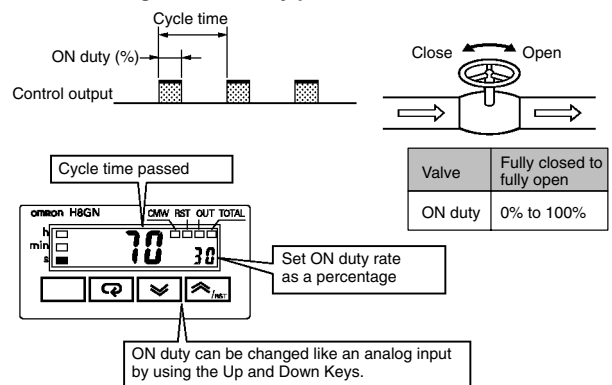

Refer to **Input/Output Mode Settings** on page 21 for information on ON/OFF-duty adjustable flicker mode operation.

## Initial Setting Level

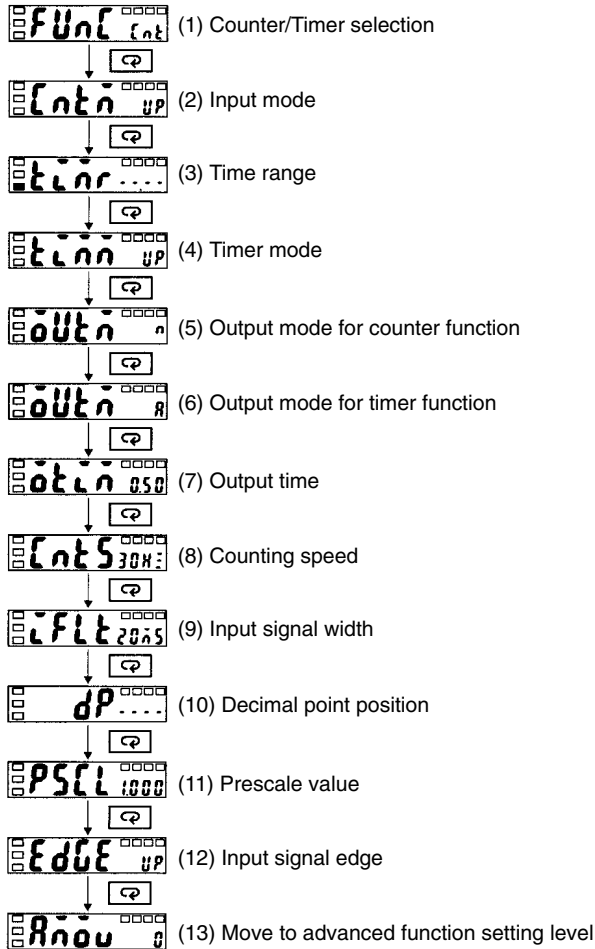

### 1. Counter/Timer Selection (FUN)

Select to use the H8GN as either a counter or a timer.

### 2. Input Mode (CNT)

**The input mode is displayed only when “Counter/Timer selection” in the initial setting level has been set to counter.**

When the H8GN is to be used as a counter, select increment, decrement, individual, or quadrature for the input mode. If increment or decrement is selected, the input signal edge for CP1 (count input) can be switched using the input signal edge setting.

Refer to *Input/Output Modes and Count Values* on page 20 for information on input mode operations.

### 3. Time Range (TR)

**The time range is displayed only when “Counter/Timer selection” in the initial setting level has been set to timer.**

When the H8GN is to be used as a timer, set the time range to be timed.

### 4. Timer Mode (TM)

**The timer mode is displayed only when “Counter/Timer selection” in the initial setting level has been set to timer.**

When the H8GN is to be used as a timer, set the elapsed or remaining time mode.

### 5. Output Mode for Counter Function (OUT)

**The output mode is displayed only when “Counter/Timer selection” in the initial setting level has been set to counter.**

When the H8GN is to be used as a counter, set the output mode. Refer to *Input/Output Mode Settings* on page 21 for information on output mode operations.

### 6. Output Mode for Timer Function (OUT)

**The output mode is displayed only when “Counter/Timer selection” in the initial setting level has been set to counter.**

When the H8GN is to be used as a timer, set the output mode. Refer to *Input/Output Mode Settings* on page 21 for information on output mode operations.

### 7. Output Time (OT)

**The output time is displayed only when “output mode for counter function” in the initial setting level has been set to C or K or when “output mode for timer function” in the initial setting level has been set to A or B.**

When using one-shot output in the H8GN, set the output time for the one-shot output (0.01 to 99.99 s).

One-shot output can be used only when the C or K output mode is selected for counter function or A or B output mode is selected for timer function.

If the output time is set to “0” when selecting timer function, the output will be held. The output time cannot be set to “0” for counter function.

### 8. Counting Speed (CS)

**The counting speed is displayed only when “Counter/Timer selection” in the initial setting level has been set to counter.**

When the H8GN is used as a counter, the operator can switch between maximum counting speeds (30 Hz/5 kHz) for CP1 and CP2.

Set to 30 Hz when using a contact for the input signal. When the counting speed is set to 30 Hz, input signal chattering is removed.

### 9. Input Signal Width (FL)

Switches between minimum input signal widths (20 ms/1 ms) for start, reset and gate inputs. All input signal widths are set together via external input.

When the counter function is selected, only the reset input is set, but when the timer function is selected the start, gate, and reset inputs are all set together.

Set to 20 ms when using a contact for the input signal. When the input signal width is set to 20 ms, input signal chattering is removed.

### 10. Decimal Point Position (DP)

**The decimal point position is displayed only when “Counter/Timer selection” in the initial setting level has been set to counter.**

This determines the decimal point position for PV, SV, SV-bank (SV 0 to 3), and totalizing count values. Press the Key to move the decimal point to the left and press the Key to move it to the right.

### 11. Prescale Value (PS)

**The prescale value is displayed only when “Counter/Timer selection” in the initial setting level has been set to counter.**

Converts the counter input pulse to any value within the setting range (0.001 to 9.999).

Example: To have a display of  $\square\square.\square\square$  m for a system that outputs 25 pulses when the object has been moved forward 0.5 m, perform the following steps.

1. Set the decimal point position to before the second-last digit.
2. Set the prescale value to 0.02 ( $0.5 \div 25$ ).

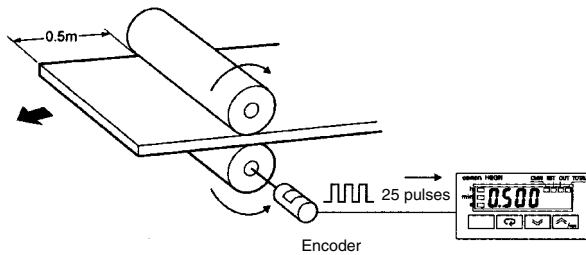

## 12. Input Signal Edge ( $EDGE$ )

The input signal edge will be displayed only when the “input mode” at the initial setting level has been set to increment or decrement.

Switches the CP1 input edge when the H8GN is used as an incrementing or decrementing counter. In the counter increment or decrement modes, CP2 will function as the gate input and CP1 counting will be prohibited while CP2 is ON.

Refer to *Input/Output Modes and Count Values* on page 20 for information on input mode operations.

## 13. Move to Advanced Function Setting Level ( $ADV$ )

This will be displayed only when the “initial setting/communications protection” in protect level is set to 0.

This setting enables the advanced function settings to utilize the counter/timer functions to the maximum. To move to the advanced function setting level, enter the password (-169) from the initial setting level.

### Advanced Function Setting Level

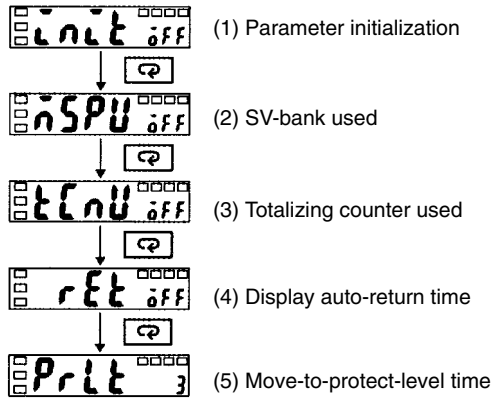

#### 1. Parameter Initialization (LnLt)

Used to return all settings to default values.  
Turn ON parameter initialization and shift to another display to return all settings to default values.

#### 2. SV-bank Used (nSPU)

Set "SV-bank used" to ON and operate the keys from the panel to switch between SV 0 to 3.  
To use the SV-bank function, the set value (SV 0 to 3) must be set beforehand in the adjustment level. These set value are then used during operation by operating the keys on the front of the Unit.

#### 3. Totalizing Counter Used (tLnU)

Set totalizing counter use to ON to display and enable use of the totalizing counter in the operation level.  
The totalizing counter displays the leftmost four digits of the 8-digit totalizing count on No. 1 display and the rightmost four digits on No. 2 display to enable 8-digit counting.

#### 4. Display Auto-return Time (rEt)

If this function is used, the display in the operation and adjustment levels will automatically return to the PV/SV display if no key operations have been made for the set period. (setting range: 1 to 99 s.)  
The time before auto-return of the display can be set here. If this setting is set to OFF, the auto-return function will not operate.

#### 5. Move-to-protect-level Time (PrLt)

If the and Keys are pressed for more than 3 seconds in the operation level, the display will move to the protect level. Use this setting to change the time that the key must be pressed to any time within the setting range (3 to 30 s).

### Protect Level

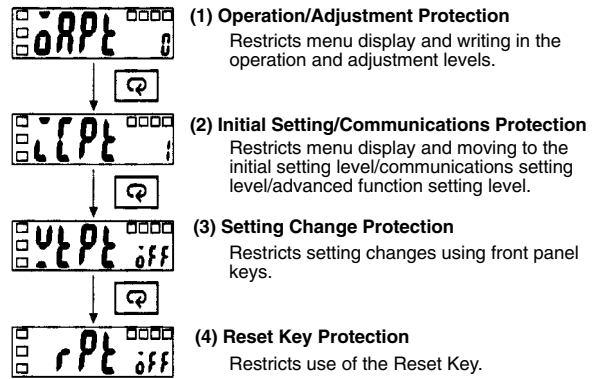

#### 1. Operation/Adjustment Protection (oAPt)

The following table shows the protection given for each setting level.

Setting level	Operation level		Adjustment level
	PV/SV	Other	
0	Not protected	Not protected	Not protected
1	Not protected	Not protected	No display, no level shift
2	Not protected	No display, no level shift	No display, no level shift
3	Display only	No display, no level shift	No display, no level shift

Not protected: Display and setting changes are possible.  
Display only: Display is possible.  
No display, no level shift: Display and level shifts are not possible.  
The initial setting level is 0 and no protection is given at this setting level.

#### 2. Initial Setting/Communications Protection (iCPt)

Moving to initial setting, communications setting, or advanced function setting levels is restricted.

Setting	Initial setting level	Communications setting level	Advanced function setting level
0	OK	OK	OK
1	OK	OK	NO
2	NO	NO	NO

OK: Move to other levels possible  
NO: Move to other levels not possible  
The default setting is 1.

#### 3. Setting Change Protection (uCPt)

Restricts setting changes using front panel keys.

Setting	Meaning
OFF	Settings can be changed by key operation.
ON	Settings cannot be changed by key operation. (Only protect level settings can be changed.)

The default setting is OFF.

#### 4. Reset Key Protect (rPt)

Prohibits the use of the Reset Key.

Setting	Meaning
OFF	PV and totalizing count values can be reset by the Reset Key.
ON	PV and totalizing count values cannot be reset by the Reset Key.

The default setting is OFF.

## Communications Setting Level





The communications specifications are set in the communications setting level. Make the individual communications settings from the front panel.

The communications parameters and their settings are listed in the following table.

Parameter	Display	Settings	Set value
Communications unit number	U-nō	0 to 99	0 / 1 to 99
Baud rate	bPS	1.2, 2.4, 4.8, or 9.6 (kbps)	1.2 / 2.4 / 4.8 / 9.6
Communications data length	LEn	7/8 (bits)	7 / 8
Stop bits	Sb̄t	1/2	1 / 2
Parity	P-r̄t̄y	None, even, or odd	nōnE / EUEn / odd

- Note:**
- The settings shown in reverse video are the default settings.
  - Settings made in the communications setting level are enabled when the power is turned ON again.

Before performing communications, perform the following procedure with the front panel keys to set the communications unit number, baud rate, and other settings. Refer to the communications manual for operation methods for other communications settings.

- Press the  Key for at least 3 seconds and move from the operation level to the initial setting level.
- Press the  Key and move from the initial setting level to the communications setting level.
- Press the  Key to change the settings items as shown below.
- Use the  and  Keys to change the settings data.

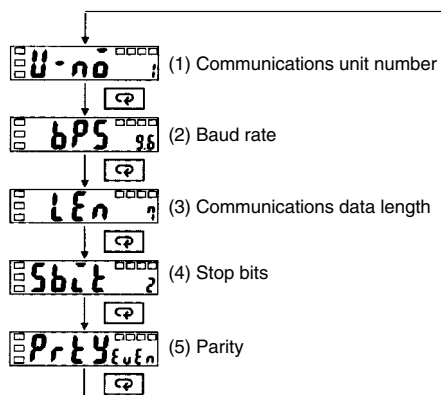

Align each communications setting with the settings on the personal computer or other communications device.

### 1. Communications Unit Number (U-nō)

When communicating with a host computer, set a unit number to enable the host computer to identify each unit. The number can be set in a range from 0 to 99 in increments of 1. The default unit number is 1. When using multiple units, the units will not function normally if the same unit number is set for more than one unit.

### 2. Baud Rate (bPS)

Set the baud rate for communications with the host computer. The settings correspond to the following baud rates.

1.2 (1,200 bps), 2.4 (2,400 bps), 4.8 (4,800 bps), and 9.6 (9,600 bps).

### 3. Communications Data Length (LEn)

The communications data length can be changed to either 7 or 8 bits.

### 4. Stop Bits (Sb̄t)

The stop bits can be set to either 1 or 2.

### 5. Parity (P-r̄t̄y)

The parity can be set to none, even, or odd.

# Parameters

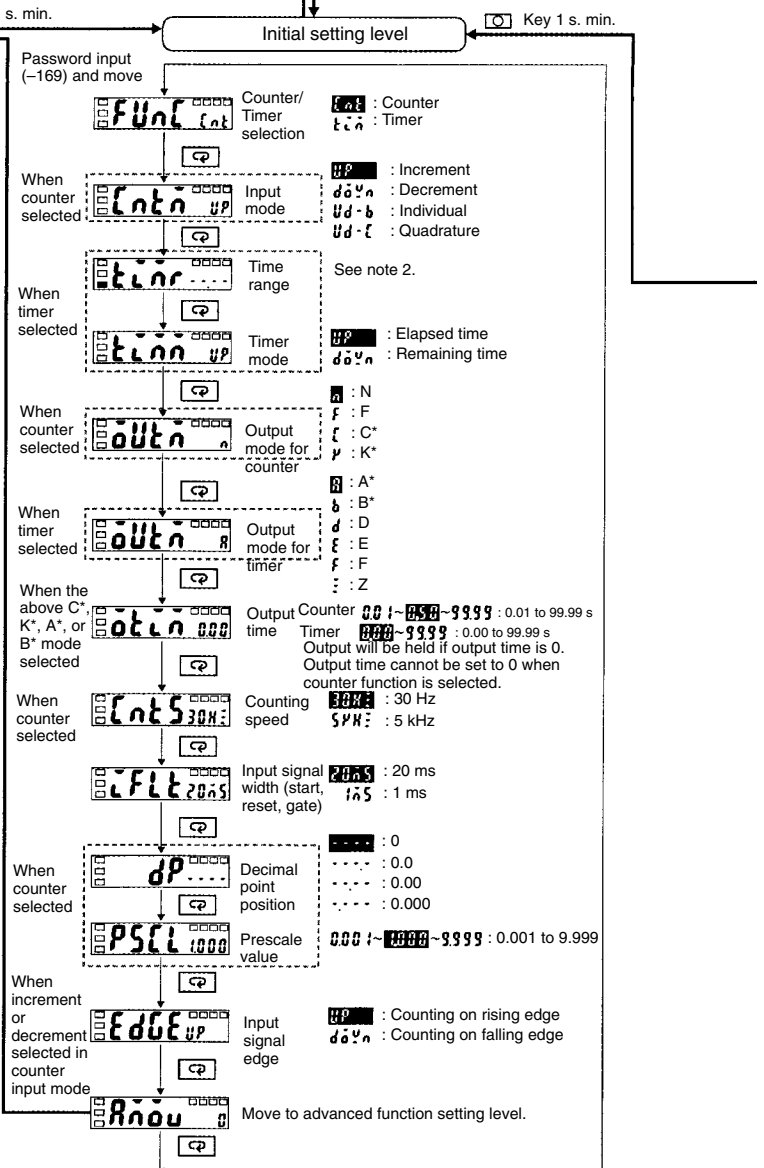
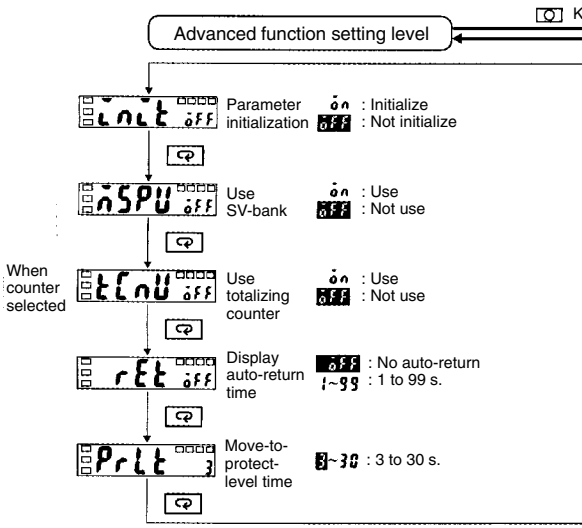
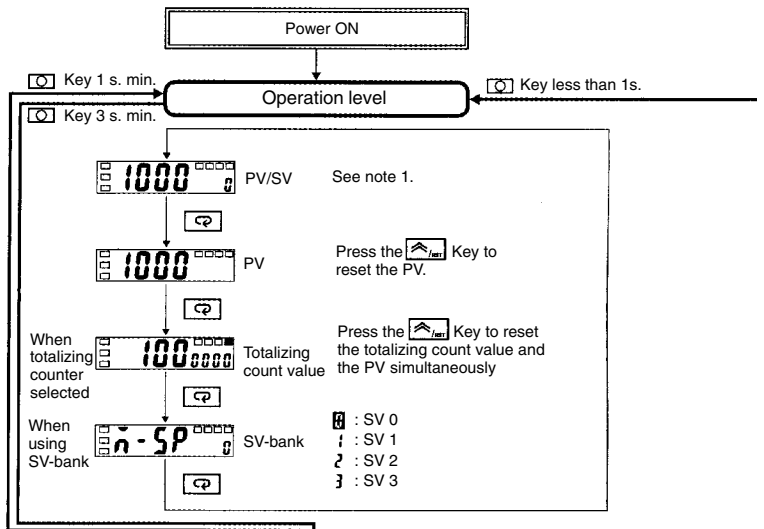
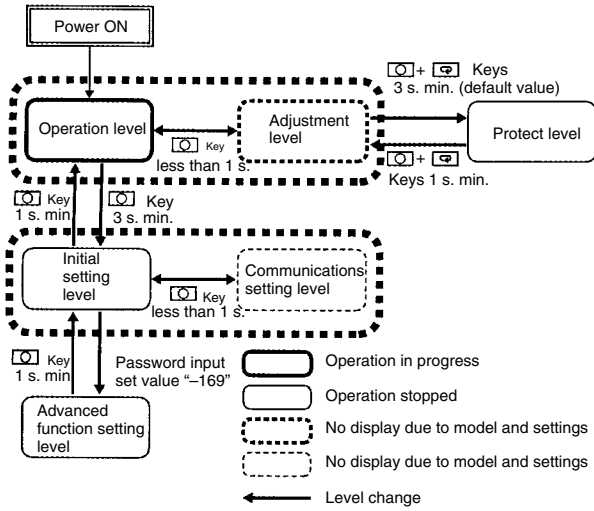

Note : The parameters shown in reverse video are the default settings.

See note 3.

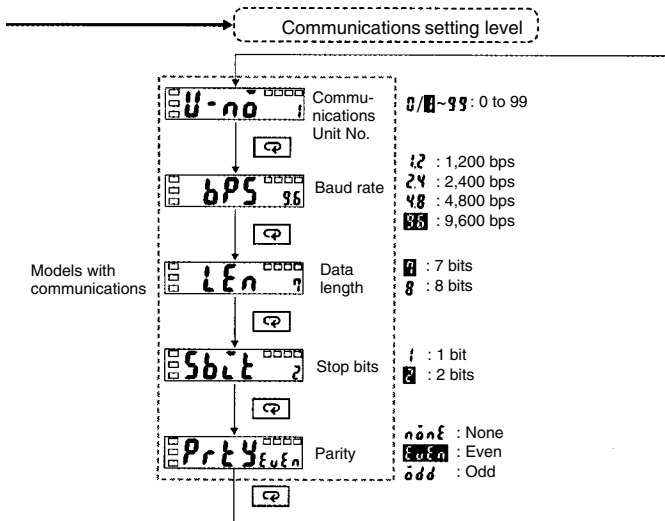
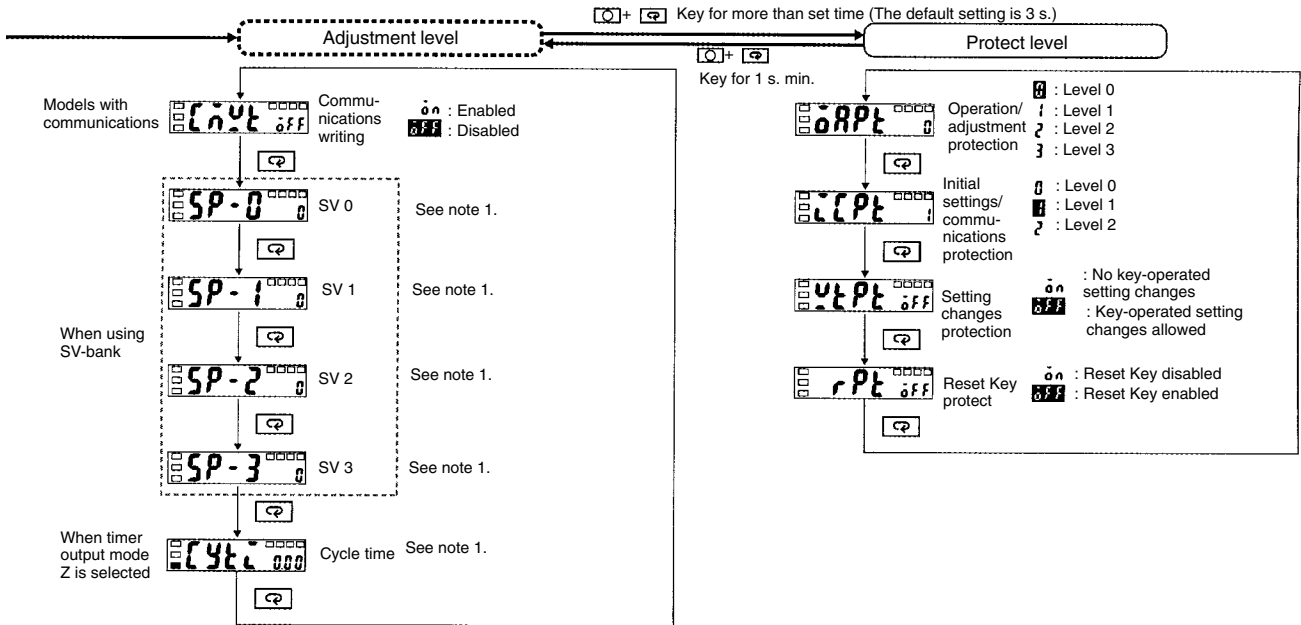

**Note :** Settings made in the communications setting level are enabled when the power is turned ON again.

- Note:**
- Counter (increment or decrement)
    - 0~9999 : 0 to 9999
    - Counter (individual or quadrature)
      - 999~0~9999 : -999 to 9999
    - Timer (cycle time or mode other than output mode Z)
      - 0.000~9.999 : 0.000 to 9.999 s
      - 0.00~9.999 : 0.00 to 99.99 s
      - 0.0~9.999 : 0.0 to 999.9s, min, h
      - 0~9.999 : 0 to 9999 s, h
      - 0.00~9.999 : 0 min 00 s to 99 min 59 s
      - 0.00~9.999 : 0 h 00 min to 99 h 59 min
    - Timer (output mode Z)
      - 0~100 : 0% to 100% (ON duty)

2. Time range

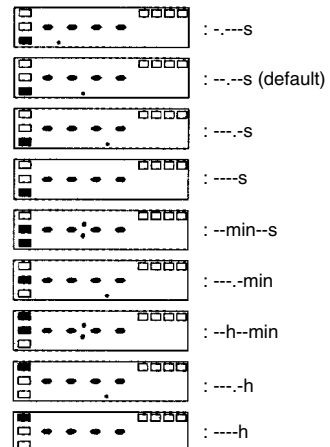

3. Displayed when level 0 is selected for initial setting/communications protection in the protect level.

# Operating Mode

## Input/Output Modes and Count Values

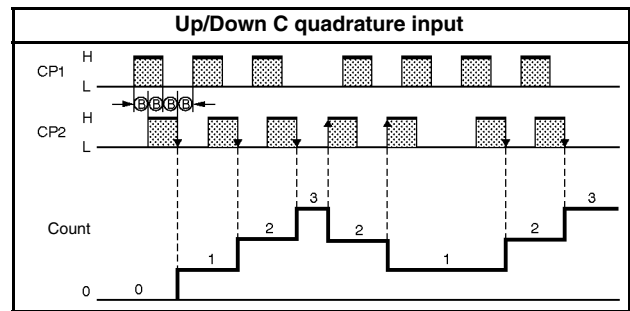
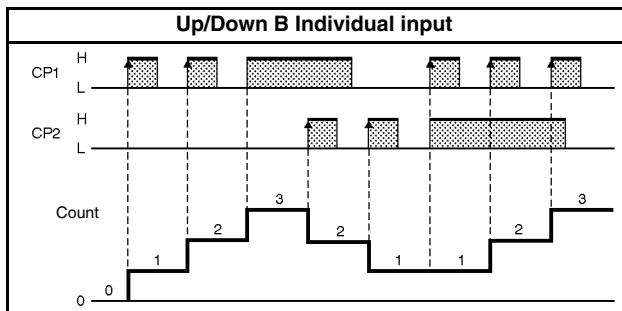
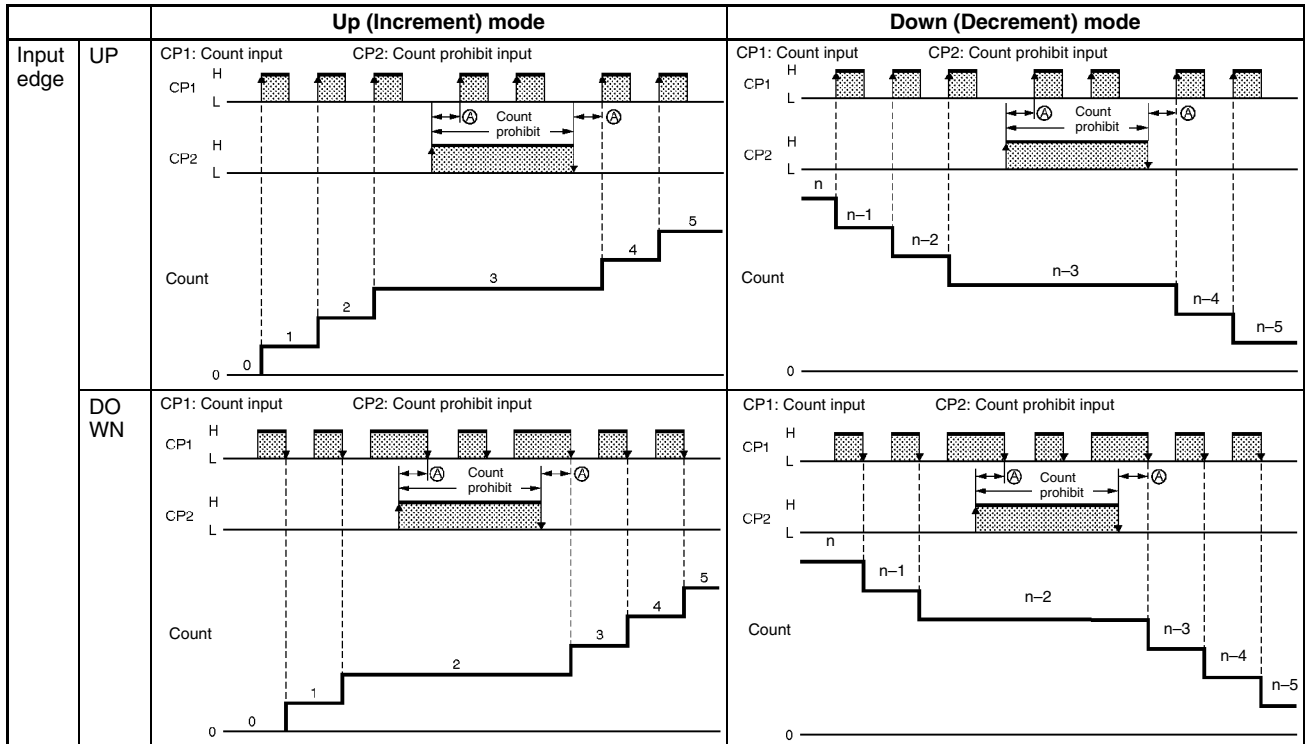

**Note:** 1. (A) indicates the minimum signal width and (B) requires at least 1/2 the minimum signal width. If these conditions are not met, a counting error (+1 or -1) may occur.

2. The following table explains the L and H symbols in the above graphics.

Symbol	Input
H	Short-circuited
L	Open

■ Input/Output Mode Settings

Counter Function

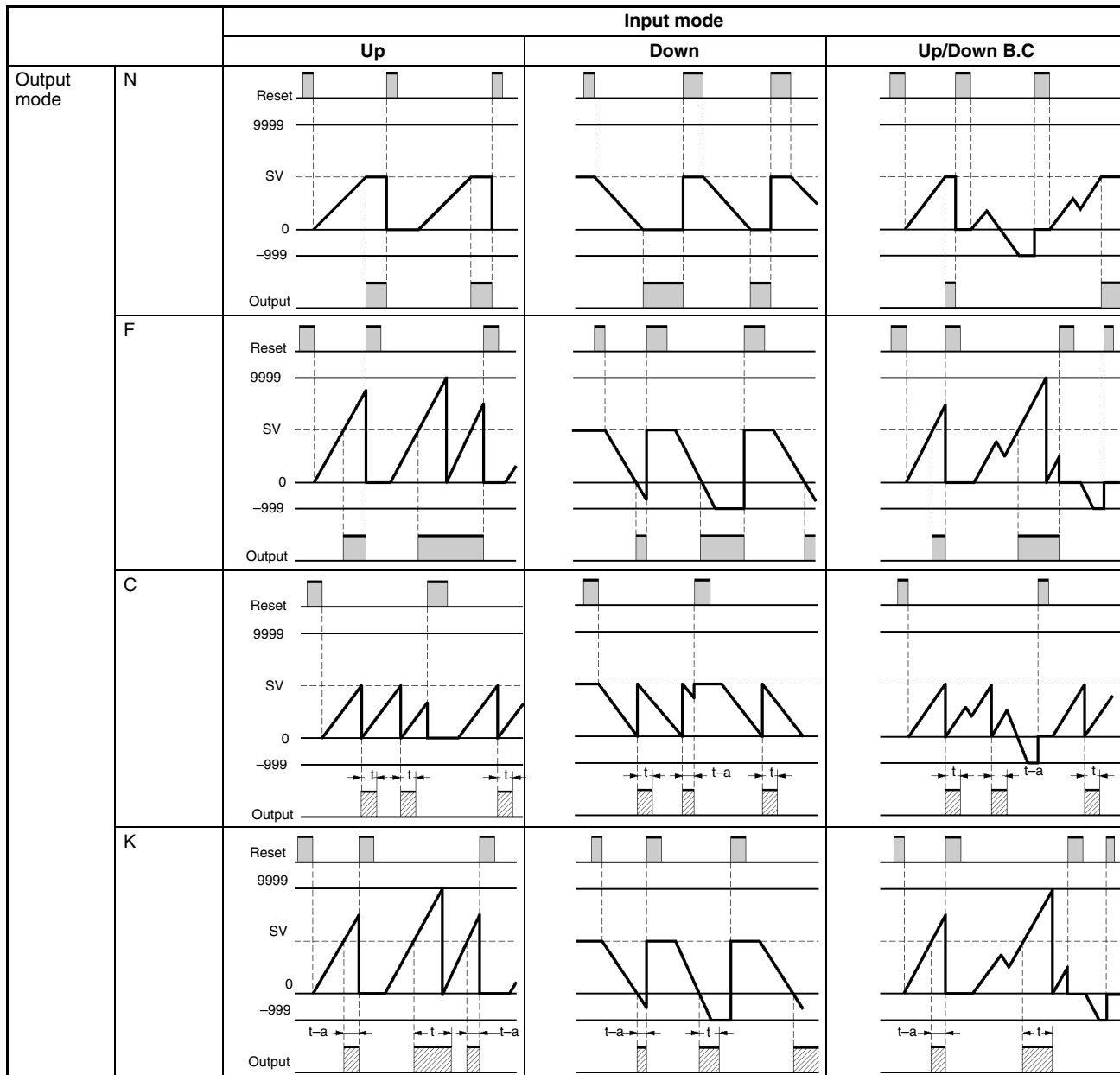

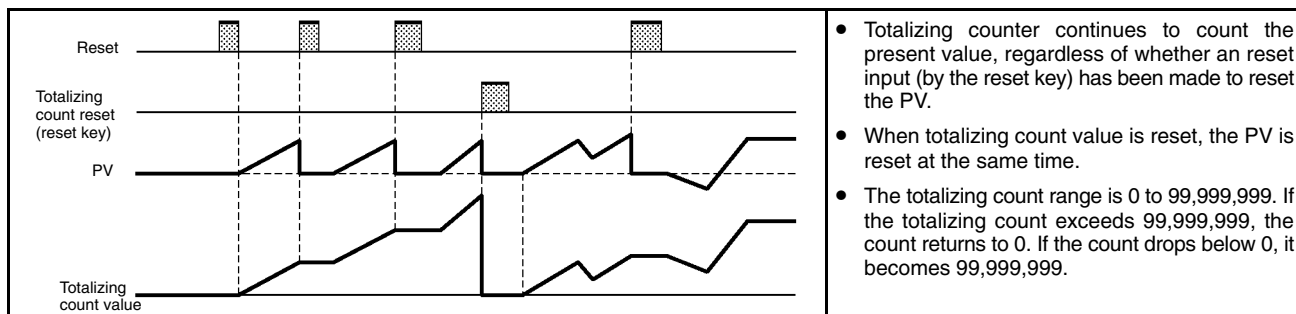

- Note:**
1.  $t$ : output time.  $t - a < t$ : Less than the output time.
  2. If there is a power failure during output ON, output will turn ON again when the power supply has recovered. For one-shot output, an output will be made again for the duration of the output time setting once the power supply has resumed.
  3. Output timing restarted during one-shot outputs is ignored.

Totalizing Counter Operation

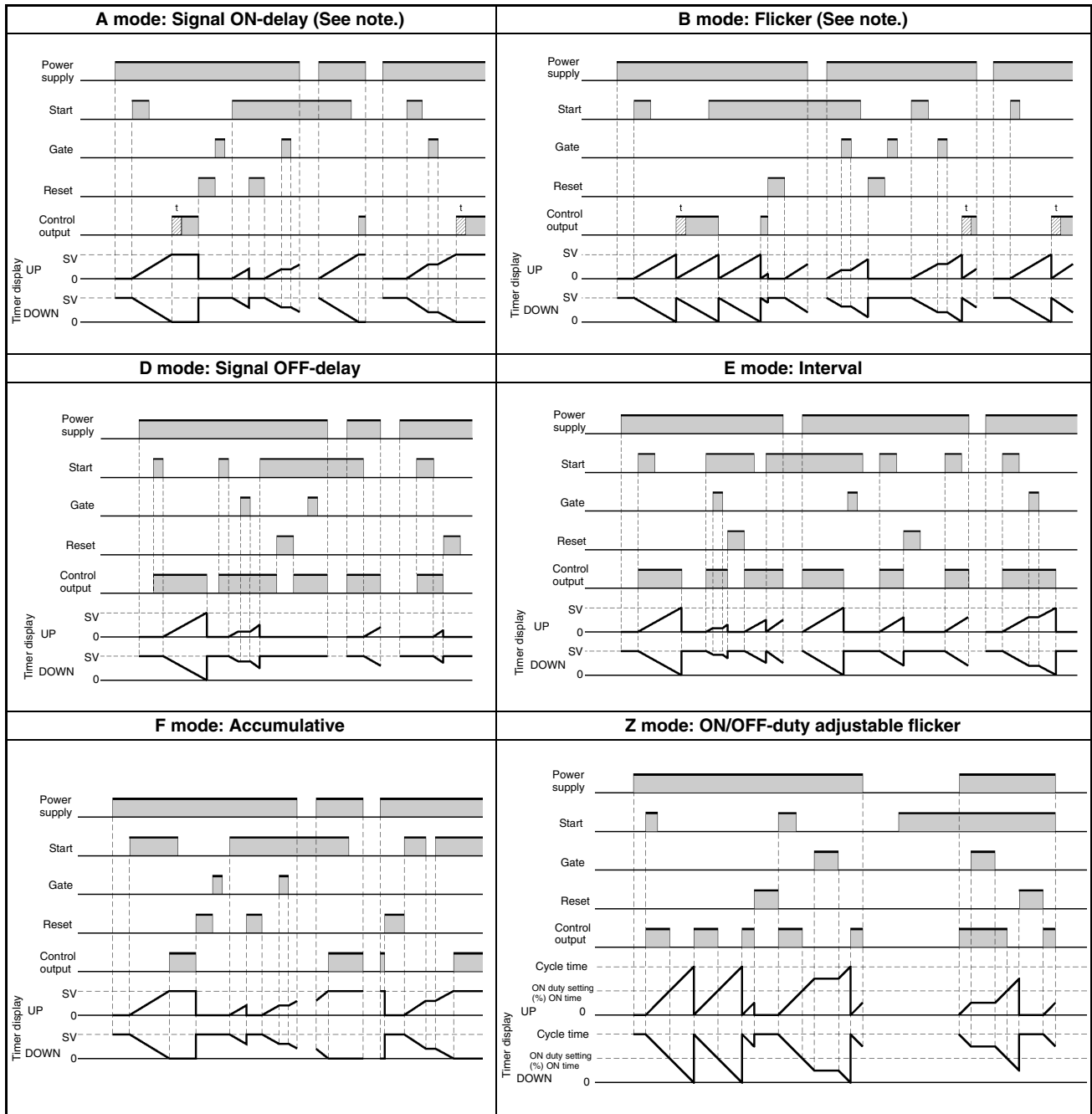

Timer Function



**Note:** One-shot output or HOLD output can be selected for output: 

**Z Mode**

Output quantity can be adjusted by changing the cycle time set in the adjustment level to 1 and by changing the ON duty (%) set value. The set value shows the ON duty (%) and can be set to a value between 0 and 100 (%). When the cycle time is 0, the output will always be OFF. When the cycle time is not 0 and when ON duty has been set to 0 (%), the output will always be OFF. When ON duty has been set to 100 (%), the output will always be ON.

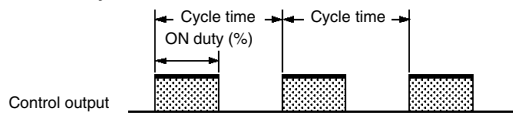

# Troubleshooting

When an error occurs, the error code is displayed on the main display. Take countermeasures according to the code.

No. 1 display	No. 2 display	Error contents	Countermeasure
E111	No display	Memory error (RAM)	Turn the power OFF and ON again. If normal operation is still not restored, it may be necessary to repair or replace the H8GN. If normal operation is restored by turning the power supply OFF and ON, it is possible that there is noise interference. Check that there is nothing in the vicinity that may be the source of noise.
E111	SU $\bar{n}$	Memory error (EEP)	
E1	No display	CPU error	This is not an actual error. This display indicates that the present value has dropped to a value less than -999. Reset using reset input or pressing the Up Key when "----" is displayed.
---- Flashes (0.5 s)	Set value displayed or no display	Present value underflow	

**Note:** Error codes are displayed only if PV/SV or PV is being displayed.

# Dimensions

**Note:** All units are in millimeters unless otherwise indicated.

## H8GN

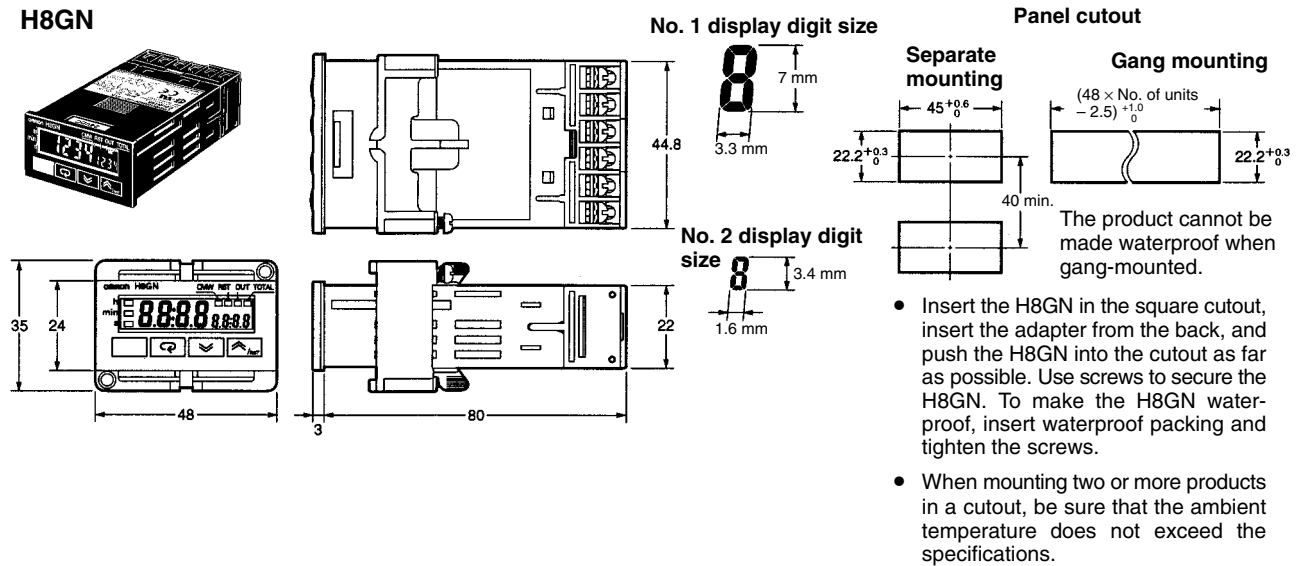

# Installation

## Terminal Arrangement

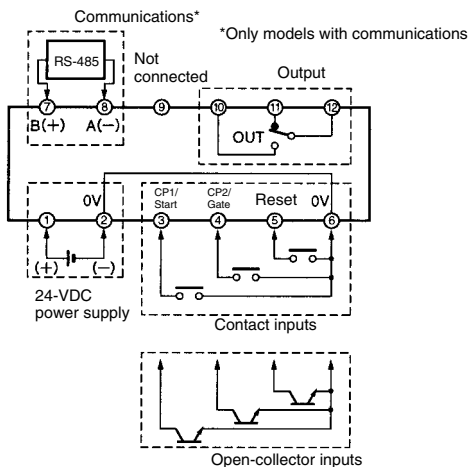

**Note:** (2) and (6) are connected internally. Do not use unused terminals as relay terminals.

## Wiring

Use the following type of crimp terminals for M3 screw.

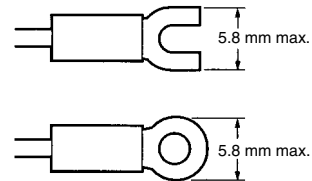

## Precautions

### ! Caution

Do not use the product in locations subject to flammable or explosive gases. Doing so may result in explosion.

### ! Caution

The service life of the output relays depends on the switching capacity and switching conditions. Consider the actual application conditions and use the product within the rated load and electrical service life. Using the product beyond its service life may result in contact deposition or burning.

### ! Caution

Do not disassemble, repair, or modify the product. Doing so may result in electric shock, fire, or malfunction.

### ! Caution

Do not allow metal objects or conductive wires to enter the product. Doing so may result in electric shock, fire, or malfunction.

### Other Precautions

- Store at the specified temperature. If the H8GN has been stored at a temperature of less than  $-10^{\circ}\text{C}$ , allow the H8GN to stand at room temperature for at least 3 hours before use.
- Use the product within the ratings specified for vibration, shock, submerging in water, and exposure to oil.
- Do not use the product in locations subject to dust, corrosive gases, or direct sunlight.
- Use the product within the ratings specified for temperature and humidity.
- The product is designed for 24 VDC. Applying voltages other than the rated one such as 100 to 240 VAC may damage the internal elements.
- Separate the input signal devices, input signal cables, and the product from the source of noise or high-tension cables producing noise.
- Separate the product from the source of static electricity when using the product in an environment where a large amount of static electricity is produced (e.g., forming compounds, powders, or fluid materials being transported by pipe).
- Do not expose the product to organic solvent such as thinner or benzene, strong alkali materials, or strong acid materials. Doing so may damage the product surface.

### Application Precautions

1. Do not use the product in locations where condensation may occur due to high humidity or where temperature changes are severe.
2. Be sure to wire terminals correctly, with the correct polarity.
3. Maintain the power supply voltage within the allowable ranges.
4. Connect the power supply through a relay or switch so that the voltage reaches a fixed value immediately. If the voltage increases gradually the power supply may be reset or outputs may turn ON.
5. When the power is turned ON, an inrush current (approx. 15 A) will flow momentarily. Depending on power supply capacities, the product may not start due to this leakage current. The power supply must be of a sufficiently large capacity.

6. For the main power supply or the power supply for input devices, use a power supply transformer whose primary side is insulated from the secondary side and whose secondary side is not grounded.
7. Leaving the H8GN with outputs ON at a high temperature for a long time may hasten the degradation of internal parts (such as electrolytic capacitors). Therefore, use the product in combination with relays and avoid leaving the product as long as more than 1 month with the output turned ON.

### Power Supplies

When turning the power ON and OFF, input signal reception is possible, unstable, or impossible as shown in the diagram below.

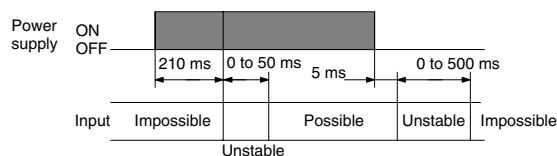

Turn the power ON and OFF using a relay with a rated capacity of 15 A minimum to prevent contact deterioration due to inrush current caused by turning the power ON and OFF.

When power is turned ON, a starting current flows momentarily. Therefore, pay attention to the overcurrent detection level of the power supply used.

### Timer Control with Power Start

To allow for the startup time of peripheral devices (sensors, etc.), the H8GN starts timing operation between 210 to 260 ms after power is turned ON (see diagram above). For this reason, in operations where timing starts from power ON, the time display will actually start from 258 ms. If the set value is 258 ms or less, the time until output turns ON will be a fixed value between 210 and 260. (Normal operation is possible for set value of 259 ms or more.) In applications where a set value of 258 ms or less is required, use start timing with signal input.

When the H8GN is used with power start in F mode (i.e., accumulative operation with output on hold), there will be a timer error (approximately 100 ms each time the H8GN is turned ON) due to the characteristics of the internal circuitry. Use the H8GN with signal start if timer accuracy is required.

### Changing the Set Value

#### In Counter Operation

When changing the set value during operation, the output will turn ON if the set value equals the present value.

#### In Timer Operation

When changing the set value during operation, if the set value is changed in so that the conditions below are satisfied, the Timer operates in the same way as when the present value reaches the set value because a constant read-in system is in use. Depending on the output mode, this may result in output turning ON.

Timer mode UP: Present value  $\geq$  set value  
 Timer mode DOWN: Elapsed time  $\geq$  set value  
 (Present value = 0)

**Note:** When in DOWN mode, the amount set value is changed is added to or subtracted from the present value.

**Operation with a Set value of 0**

**In Counter Operation**

The output will turn ON if the set value (0) equals the present value. The output will be OFF while the Reset Key is pressed or the reset input is ON.

**In Timer Operation**

- a) When the output mode is set to A, B (one-shot output), D, or F, output will turn ON when the start signal is input.
- b) When the output mode is set to B (hold output), E, or Z, output will remain OFF even when the start signal is input.

**Response Delay Time When Resetting**

The following table shows the delay from when the reset signal is input until the output is turned OFF.

Minimum reset signal width	Output delay time
1 ms	3.7 to 6.0 ms
20 ms	19 to 21 ms

**Output Delay Time**

The following table shows the delay from when the timer value passes the set value until the output is produced.

**Actual Measurements in N or K Mode**

Control output	Max. counting speed	Output delay time*
Contact output	30 Hz	17.3 to 18.9 ms
	5 kHz	3.5 to 5.2 ms

\*The variation in delays is due to different modes and conditions.

**Mounting**

Tighten the two mounting screws on the Adaptor. Tighten them alternately, a little at a time, so as to keep them at an equal tightness.

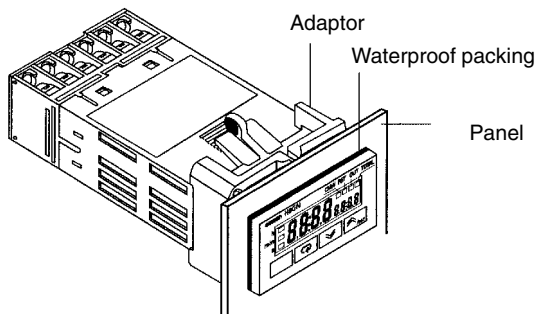

The H8GN's panel surface is water-resistant (conforming to NEMA 4X (indoors) and IP66). In order to prevent the internal circuit from water penetration through the space between the Counter and operating panel, attach a rubber packing (provided with the H8GN) between the Counter and operating panel and secure the rubber packing with the Y92F-34 Flush-mounting Adaptor.

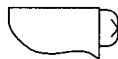

**Output**

The SPDT (single-pole, double-throw) consists of an SPST-NO contact and an SPST-NC contact. Do not form a circuit with 3-point short-circuit (power short-circuiting with arc).

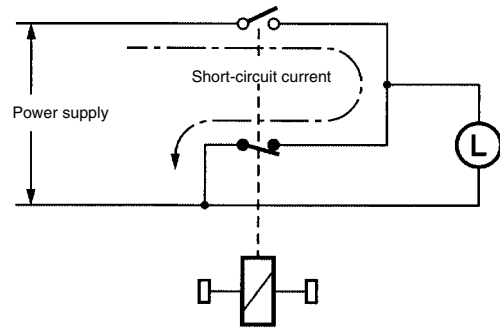

**Reference**

For details about communications functions, refer to H8GN Preset Counter/Timer User's Manual (Catalog No. M066).

# Appendix

## ■ Parameters List

Fill in your set values in the *Set value* column of the following tables and utilize the tables for quick reference.

### Protect Level

Parameter name	Parameter	Setting range	Default value	Unit	Set value
Operation/Adjustment Protection	$\bar{o}APL$	0 to 3	0		
Initial Setting/Communications Protection	$\bar{i}CPL$	0 to 2	1		
Setting Change Protection	$\bar{s}tPL$	$\bar{o}n/\bar{o}FF$	$\bar{o}FF$		
Reset Key Protection	$\bar{r}PL$	$\bar{o}n/\bar{o}FF$	$\bar{o}FF$		

### Operation Level

Parameter name		Parameter	Setting (display) range	Default value	Unit	Set value	
Present value (PV)/ Set Value (SV)	PV	Counter	-999 to 9999/---- (PV<-999)	0			
		Timer		0.000 to 9.999 (Time range=-.---s)	0.000	Second	
				0.00 to 99.99 (Time range=-.-s)	0.00	Second	
				0.0 to 999.9 (Time range=---s)	0.0	Second	
				0 to 9999 (Time range=----s)	0	Second	
				0:00 to 99:59 (Time range=-min--s)	0:00	Minute: Second	
				0.0 to 999.9 (Time range=---.min)	0.0	Minute	
				0:00 to 99:59 (Time range=-h--min)	0:00	Hour: Minute	
				0.0 to 999.9 (Time range=----h)	0.0	Hour	
				0 to 9999 (Time range=----h)	0	Hour	
	SV	Counter		0 to 9999 (Input mode=Up or Down)	0		
				-999 to 9999 (Input mode=Individual or quadrature)	0		
		Timer (Output mode: A, B, D, E, F)		0.000 to 9.999 (Time range=-.---s)	0.000	Second	
				0.00 to 99.99 (Time range=-.-s)	0.00	Second	
				0.0 to 999.9 (Time range=---s)	0.0	Second	
				0 to 9999 (Time range=----s)	0	Second	
				0:00 to 99:59 (Time range=-min--s)	0:00	Minute: Second	
				0.00 to 999.9 (Time range=---.min)	0.0	Minute	
				0:00 to 99:59 (Time range=-h--min)	0:00	Hour: Minute	
				0.00 to 999.9 (Time range=----h)	0.0	Hour	
	0 to 9999 (Time range=----h)	0	Hour				
	Timer (Output mode: Z)	0 to 100	0	%			
PV			Same as for PV in the above PV/SV column.				
Totalizing count value			0 to 99999999	0			
SV-bank		$\bar{n}SP$	0/1/2/3	0			

## Adjustment Level

Parameter name	Parameter	Setting range	Default value	Unit	Set value
Communications writing control	$CnWt$	$on/off$	$off$		
SV 0	$SP-0$	Same as for PV in the above PV/SV column.			
SV 1	$SP-1$	Same as for PV in the above PV/SV column.			
SV 2	$SP-2$	Same as for PV in the above PV/SV column.			
SV 3	$SP-3$	Same as for PV in the above PV/SV column.			
Cycle time	Timer (Output mode=Z)	$CYtC$	0.000 to 9.999 (Time range=--s)	0.000	Second
			0.00 to 99.99 (Time range=--s)	0.00	Second
			0.0 to 999.9 (Time range=---s)	0.0	Second
			0 to 9999 (Time range=----s)	0	Second
			0:00 to 99:59 (Time range=--min--s)	0:00	Minute: Second
			0.0 to 999.9 (Time range=---min)	0.0	Minute
			0:00 to 99:59 (Time range=--h--min)	0:00	Hour: Minute
			0.0 to 999.9 (Time range=---h)	0.0	Hour
		0 to 9999 (Time range=----h)	0	Hour	

## Initial Setting Level

Parameter name	Parameter	Setting range	Default value	Unit	Set value
Counter/Timer selection	$FUnC$	$Cnt/tCn$	$Cnt$		
Input mode	$Cntn$	$UP/d\bar{d}Yn/Ud-b/Ud-C$	$UP$		
Time range	$tCnr$	$---S/--S/---S/---S/---Cn--S/---n\bar{C}n/--H--n\bar{C}n/---H0---H$	$---$	Second	
Timer mode	$tCnn$	$UP/d\bar{d}Yn$	$UP$		
Output mode for counter function	$\bar{d}Ut\bar{n}$	$n/F/C/P$	$n$		
Output mode for timer function	$\bar{d}Ut\bar{n}$	$R/b/d/E/F/E$	$R$		
Output time	Counter	$\bar{d}tCn$	0.01 to 99.99	0.50	Second
	Timer		0.00 to 99.99	0.00	Second
Counting speed	$CntS$	$30Hz/5Hz$	$30Hz$		
Input signal width	$CFLt$	$20nS/1nS$	$20nS$		
Decimal point position	$dP$	$---/----/----/----$	$---$		
Prescale value	$P5CL$	0.001 to 9.999	1.000		
Input signal edge	$E\bar{d}GE$	$UP/d\bar{d}Yn$	$UP$		
Move to function setting level	$Rn\bar{d}U$	-999 to 9999	0		

## Communications Setting Level

Parameter name	Parameter	Setting range	Default value	Unit	Set value
Communications unit number	$U-n\bar{d}$	0 to 99	1		
Baud rate	$bPS$	1.2/2.4/4.8/9.6	9.6	kbps	
Communications data length	$LEn$	7/8	7	bit	
Stop bits	$Sb\bar{C}t$	1/2	2	bit	
Parity	$Pr\bar{t}Y$	$n\bar{d}nE/EuEn/\bar{d}d$	$EuEn$		

## Advanced Function Setting Level

Parameter name	Parameter	Setting range	Default value	Unit	Set value
Parameter initialization	$\bar{C}n\bar{C}t$	$\bar{0}n/\bar{0}FF$	$\bar{0}FF$		
SV-bank used	$\bar{n}SPU$	$\bar{0}n/\bar{0}FF$	$\bar{0}FF$		
Totalizing counter used	$\bar{t}CnU$	$\bar{0}n/\bar{0}FF$	$\bar{0}FF$		
Display auto-return time	$rEt$	$\bar{0}FF/1$ to $99$	$\bar{0}FF$	Second	
Move-to-protect-level time	$P-rLt$	$3$ to $30$	$3$	Second	

**ALL DIMENSIONS SHOWN ARE IN MILLIMETERS.**

To convert millimeters into inches, multiply by 0.03937. To convert grams into ounces, multiply by 0.03527.

Cat. No. M065-E1-1A In the interest of product improvement, specifications are subject to change without notice.

## OMRON Corporation

Industrial Automation Company

Measuring and Supervisory Controls Department  
Shiokoji Horikawa, Shimogyo-ku,  
Kyoto, 600-8530 Japan  
Tel: (81)75-344-7108/Fax: (81)75-344-7189

Printed in Japan  
0201-1.5M (0600) (O)