

Intelligent, User-friendly Digital Controller and Programmer

- Controlled with ease with a support software which is input via the communication jack on the front panel.
- Minute adjustment of PID parameters can be done easily using fuzzy fine-tuning.
- Any available functions can be assigned to the front keys to make an optimum MMI (Man Machine Interface) that displays the items required by the user.
- The incorporated hybrid control (advanced PID and fuzzy logic) function makes high-precision control possible.
- Both cascade and proportional position control can be performed using a single controller. (Models with secondary inputs have been added for the ES100P as well.)
- Analog and digital processing can be combined.
- 400 steps max. are possible with the ES100P (99 program patterns, 99 steps).



Ordering Information

These models are not provided with a Control Output Unit. Be sure to specify the Control Output Unit when ordering.

■ Temperature/Process Controllers ES100X Controller

Standard and Heating/Cooling Controllers*

Transmission output	None	4 to 20 mA				
Communications	None			RS-232C	RS-422/485**	
Aux. I	0	3	3	8		
Aux. O	Open collector	0	0	2	8	
	Relay	2	2	2	2	
Without analog input 2	ES100X-AAH	ES100X-AAHFB	ES100X-AAHFD	ES100X-AAHFE	ES100X-AAH01FE	ES100X-AAH04FE
With analog input 2 (4 to 20 mA or 1 to 5 V)	---	ES100X-AAWHFB	---	ES100X-AAWHFE	ES100X-AAWH01FE	ES100X-AAWH04FE

Proportional Positioning Controllers***

Transmission output	4 to 20 mA				
Communications	None			RS-232C	RS-422/485**
Aux. I	3	3	8		
Aux. O	Open collector	0	2	8	
	Relay	2	2	2	
Without analog input 2	ES100X-RRPFB	ES100X-RRPFD	ES100X-RRPFE	ES100X-RRP01FE	ES100X-RRP04FE
With analog input 2 (4 to 20 mA or 1 to 5 V)	ES100X-RRPWFB	---	ES100X-RRPWFE	ES100X-RRPW01FE	ES100X-RRPW04FE

*Factory-set to standard operation.

**Factory-set to RS-422 communications.

***An Output Relay Unit is mounted at the factory.

ES100P Programmer

Standard and Heating/Cooling Controllers*

Transmission output	None	4 to 20 mA			
Communications	None		RS-232C	RS-422/485**	
Aux. I	0	3	8		
Aux. O	Open collector	0	2	8	
	Relay	2	2	2	
Without analog input 2	ES100P-AAH	ES100P-AAHFD	ES100P-AAHFE	ES100P-AAH01FE	ES100P-AAH04FE
With analog input 2 (4 to 20 mA or 1 to 5 V)	---	---	ES100P-AAWHFE	ES100P-AAWH01FE	ES100P-AAWH04FE

Proportional Positioning Controllers***

Transmission output	4 to 20 mA			
Communications	None		RS-232C	RS-422/485**
Aux. I	3	8		
Aux. O	Open collector	2	8	
	Relay	2	2	
Without analog input 2	ES100P-RRPFD	ES100P-RRPFE	ES100P-RRP01FE	ES100P-RRP04FE
With analog input 2 (4 to 20 mA or 1 to 5 V)	---	ES100P-RRPWFE	ES100P-RRPW01FE	ES100P-RRPW04FE

*Factory-set to standard operation.

**Factory-set to RS-422 communications.

***An Output Relay Unit is mounted at the factory.

■ Temperature Ranges

Thermocouples

Input		R/S	K1	K2	J1	J2	T	E
Range	°C	0 to 1,700	-200 to 1,300	0.0 to 600.0	-100 to 850	0.0 to 400.0	-199.9 to 400	0 to 600
	°F	0 to 3,000	-300 to 2,300	0.0 to 999.9	-100 to 1,600	0.0 to 750.0	-199.9 to 700	0 to 1,100

Input		B	N	L1	L2	U	W	PLII
Range	°C	100 to 1,800	0 to 1,300	-100 to 850	0.0 to 400.0	-199.9 to 400	0 to 2,300	0 to 1,300
	°F	300 to 3,000	0 to 2,300	-100 to 1,600	0.0 to 750.0	-199.9 to 700	0 to 3,000	0 to 2,300

Platinum Resistance Thermometers

Input		JPt/Pt
Range	°C	-199.9 to 600.0
	°F	-199.9 to 999.9

■ Current/Voltage Input

Input	Current				Voltage				
Range	4 to 20 mA	0 to 20 mA	0 to 10 mV	0 to 100 mV	-10 to 10 mV	0 to 1 V	1 to 5 V	0 to 5 V	0 to 10 V

■ Support Software (For Windows)

Name	Model
Support Software (CD-ROM)	ES100-YB177-E

■ Current Transformers (CT)

Model	E54-CT1	E54-CT3
Hole diameter	5.8 mm	12.0 mm

Note: The E54-CT2 cannot be used.

■ Control Output Unit

Output	ON/OFF					Linear			
	Relay output	SSR output	Voltage output (for driving SSR)			Current output		Voltage output	
			12 VDC, NPN	24 VDC, NPN	24 VDC, PNP				
Model	E53-R	E53-S	E53-Q	E53-Q3	E53-Q4	E53-C3	E53-C3D	E53-V34	E53-V35

Note: The E53-C cannot be used.

■ Product Inspection Sheet

Name	Model
Product Inspection Sheet	ES100-K

■ Cables

Name	Model	
Expansion I/O Cable	For XW2B-20G, G7TC-OC08	G79-200C-175-ES1
	For XW2B-34G (corresponding to BCD communication)	XW2Z-200C
	For G7TC-C08 (output only)	G79-200C-ES1
Cable for Support Software (see note.)	ES100-CT023-202 (9-pin)	

Note: Cable comes with support software.

■ Accessories

Name	Model
Watertight Cover	Y92A-96N
Terminal Cover	E53-COV01

■ Model Number Legend:

Controllers

ES100X - -
 1 2 3 4 5 6 7

1. Control Method and Outputs

AA: Standard, heating/cooling
RRP: Proportional positioning

2. Secondary Input

W: Yes

3. Heater Burnout Detection

H: Yes

4. Communications

01: RS-232C
04: RS-422/RS-485

5. Transmission Output

F: Yes (4 to 20 mA)

6. Digital I/O

B: Digital inputs only (3 points)
D: Digital I/O (3 input points and 2 output points)

E: Expansion digital I/O or BCD (8 input points and output points respectively)

7. Product Inspection Sheet

K: Yes

Programmiers

ES100P - -
 1 2 3 4 5 6 7

1. Control Method and Outputs

AA: Standard, heating/cooling
RRP: Proportional positioning

2. Secondary Input

W: Yes

3. Heater Burnout Detection

H: Yes

4. Communications

01: RS-232C
04: RS-422/RS-485

5. Transmission Output

F: Yes (4 to 20 mA)

6. Digital I/O

D: Digital I/O (3 input points and 2 output points)
E: Expansion digital I/O or BCD (8 input points and output points respectively)

7. Product Inspection Sheet

K: Yes

Specifications

■ Ratings

Supply voltage	100 to 240 VAC, 50/60 Hz
Operating voltage range	85% to 110% of rated supply voltage
Power consumption	Approx. 20 VA (at 100 VAC) to 25 VA (at 240 VAC)
Analog input 1 (main input)	Current input: 4 to 20 mA, 0 to 20 mA (impedance: 150Ω±10%) Voltage input: 1 to 5 V, 0 to 5 V, 0 to 1 V, 0 to 10 V, 0 to 10 mV, 0 to 100 mV, -10 to 10 mV (impedance: 1 MΩ min.) Thermocouple: R, S, K, J, T, E, B, N, L, U, PLII, W Platinum resistance thermometer: Pt100, JPt100
Analog input 2	Current input: 4 to 20 mA (impedance: 150Ω±10%) Voltage input: 1 to 5 V (impedance: approx. 1 MΩ)
CT input (see note 1)	Connect the dedicated CT (E54-CT1 or E54-CT3).
Potentiometer input (see note 1)	100 Ω to 2.5 kΩ
Control output (see note 2)	Output Unit (sold separately) (use the Output Unit to obtain a control output. The position proportional output type, however, has Relay Output Units on its socket.)
Control mode	Hybrid of fuzzy logic and advanced PID control (2-PID) with auto-tuning and fine-tuning or ON/OFF.
Auxiliary output	Relay output: two Independent outputs (SPDT and SPST-NO), 250 VAC, 3 A Open collector output: common outputs, 24 VDC ^{+10%/−15%} , max. load current: 100 mA
Transmission output	1 output, 4 to 20 mA with a load of 600 Ω max.
External signal input (auxiliary input)	Power supply: 24 VDC ^{+10%/−15%} , (the model with expansion I/O needs an external power supply) Current when the signal is ON: 3 mA max. Leakage current when the signal is OFF: 0.3 mA max.
Setting method	Digital setting with Up and Down Keys or Support Software (via RS-232C terminal on the front panel)
Indication method	Digital indications (character height: PV: 14.2 mm, SV: 10.2 mm, BANK, STEP, PTN: 7.6 mm) (color PV: red, SV: green, BANK, STEP, PTN: yellow) Bar graph indication (resolution: 10; color: green) Status of ramp and soak (displayed by green LED (ES100P only))
Other functions	Manual output Communications (RS-232C, RS-422/RS-485, BCD) Assignments (front keys, setting/display items, digital I/O, and analog I/O) Processing (four fundamental arithmetic operations, primary time-lag filters, linear approximation, broken line approximation, extraction of a square root, logical operation, average addition, average movement) ON/OFF timer Heating and cooling control (except the Proportional Positioning Model) SP setting limiter, SP rise/fall rate limiter, MV (output) change rate limiter, key protect selection etc. 8 banks (set value, event output, PID parameter, MV (output) limiter), program bank (ES100X only) Cascade control (possible with a single model with secondary input) (ES100X only) Fixed SP, time signal, step output (ES100P only)

- Note:** 1. Either a CT input or a potentiometer input is available (both of them cannot be used at the same time).
2. All control outputs are electrically insulated from the internal circuitry (except transfer output and auxiliary terminal output).

■ Output Unit Ratings

ON/OFF	Relay Output Unit	E53-R	SPDT; 5 A, 250 VAC (resistive load)
	SSR Output Unit	E53-S	SPST-NO; 1 A, 75 to 250 VAC; leakage current: 1.5 mA max. (at 200 VAC)
	Voltage Output Unit (for driving SSR)	E53-Q	40 mA max., 12 VDC; NPN (with short-circuit protection)
		E53-Q3	20 mA max., 24 VDC; NPN (with short-circuit protection)
E53-Q4		20 mA max., 24 VDC; PNP (with short-circuit protection)	
Linear	Current Output Unit	E53-C3	4 to 20 mA, DC: 600 Ω max.; resolution: approx. 2,600
		E53-C3D	0 to 20 mA, DC: 600 Ω max.; resolution: approx. 2,600
	Voltage Output Unit	E53-V34	0 to 10 VDC: 1 kΩ min.; resolution: approx. 2,600
		E53-V35	0 to 5 VDC: 1 kΩ min.; resolution: approx. 2,600

■ Current Transformer Ratings

Max. continuous heater current	50 A
Dielectric strength	1,000 VAC (for 1 min)
Vibration resistance	50 Hz (approx. 10G)
Weight	E54-CT1: Approx. 11.5 g; E54-CT3: Approx. 50 g
Accessories (E54-CT3 only)	Contact: 2; Plug: 2

■ Controller Characteristics

Item	ES100X	ES100P
Indication accuracy (see note)	Thermocouple ($\pm 0.1\%$ of indication value or $\pm 1^\circ\text{C}$, whichever greater) ± 1 digit max. Platinum resistance thermometer ($\pm 0.1\%$ of indication value or $\pm 0.5^\circ\text{C}$, whichever greater) ± 1 digit max. Voltage/current input ($\pm 0.1\%$ FS, ± 1 digit max.)	
ON/OFF control hysteresis	0.01% to 99.99% FS (in units of 0.01%)	
Proportional band	0.0% to 999.9% FS (ON/OFF control when 0.0%) 0.1% to 999.9% FS (proportional position model) (in units of 0.1%)	
Integral (reset) time	0 to 9,999 s (PD control when 0 s) (in units of 1 s)	
Derivative (rate) time	0 to 9,999 s (PI control when 0 s) (in units of 1 s)	
Fuzzy intensity	0.0% to 100.0% (Advanced PID control (2-PID) when 0.0%) (in units of 0.1%)	
Event set value	Equivalent to -200.0% to 200.0% FS of industrial value or unit	
Control period	1 to 120 s (in units of 1 s)	
Sampling period	0.1 s min. type 0.2 s (in units of 1 s)	
Display refresh period	As large as, twice as large as, 5 times as large as, or 10 times as large as control operation period	
PV compensation	Equivalent to -100.0% to 100.0% FS of industrial value or unit	
Manual manipulated value	-5.0% to 105.0%	
Manipulated value limit	Lower limit: -5.0% to -0.1% max.; upper limit: $+0.1\%$ min. to 105.0%	
Setting time (1 step)	---	0 to 99 hours 59 minutes or 0 to 99 minutes 59 seconds
Program capacity	---	Total steps 400 max. (99 patterns, 99 steps)
Programming method	---	Break point method (patterns can be decided by the user)
Insulation resistance	20 M Ω min.	
Dielectric strength	2,000 VAC, 50/60 Hz for 1 min between terminals of different polarities	
Vibration resistance	Malfunction: 10 to 150 Hz, 0.5-mm single amplitude each in X, Y, and Z directions Destruction: 10 to 150 Hz, 0.75-mm single amplitude each in X, Y, and Z directions	
Shock resistance	Malfunction: 20G max., 3 times each in 6 directions Destruction: 30G max., 3 times each in 6 directions (20G's in the forward direction)	
Ambient temperature	Operating: -10° to 55°C (with no icing) Storage: -25° to 65°C (with no icing)	
Ambient humidity	Operating: 35% to 85%	
Memory protection	Lithium cell backup (10 years at normal room temperature)	
Enclosure ratings	Front panel: IEC standard IP50 (with water proof cover: IP66, NEMA4) Rear case: IEC standard IP20 Terminals: IEC standard IP00 (with terminal cover: VDE 0106/P100)	
Weight	Approx. 800 g	

Note: Indication accuracy varies with the type of sensor and the sensing temperature as follows:
K and T sensor (-100°C max.), R, S, and W sensor (200°C max.), and U sensor: $\pm 2^\circ\text{C} \pm 1$ digit; B sensor (400°C max.): $\pm 6^\circ\text{C} \pm 1$ digit
Indication accuracy without using the built-in cold contact compensation circuit is $\pm 0.1\%$ FS or $\pm 1^\circ\text{C}$ whichever is smaller except for the following sensors:
R and S sensor (200°C max.): $\pm 1.5 \pm 1$ digit; L2 and U sensor: $\pm 1^\circ\text{C} \pm 1$ digit

■ Output Unit Characteristics

Relay Unit life expectancy	Mechanical: 10,000,000 operations min. Electrical: 100,000 operations min.
----------------------------	---

■ Heater Burnout Detection Characteristics

Max. heater current	50 A, single-phase
Monitor accuracy of input current	±5% FS ±1 digit max.
Heater burnout detection setting range	0.0 to 50.0 A (see note 1)
Heater current monitor range	0.0 to 55.0 A
Min. detectable ON time	200 ms (see note 2)

Note: 1. Heater burnout is not detected when current is set to 0.0 A; the burnout alarm will be automatically turned ON when current is set to 50.0 A.

2. When the control output is ON for less than 200 ms, heater burnout is not detected and heater current is not measured.

■ Watertight Cover Characteristics

Enclosure ratings	Front cover: IEC standard IP66, conforming to NEMA 4
-------------------	--

■ Terminal Cover Characteristics

Enclosure ratings	Conforming to VDE0106/P100
-------------------	----------------------------

■ Support Software Characteristics (For Windows)

Personal computer	Windows-compatible computer with Pentium or higher, and 800 x 600 min. display.
OS	Windows 95, Windows 98, Windows NT4.0, or Windows 2000
Main memory	16 MB for Windows 95 and Windows 98 24 MB for Windows NT and Windows 2000
Communications method	RS232C; half-duplex
Transmission speed	9,600 bps
Printer	Windows-compatible printer

■ Communications

Communications	RS-232C	RS-422	RS-485	BCD	Transmission output
Transmission method	None, half-duplex	4-wire, half-duplex	2-wire, half-duplex	Data select code method	4 to 20 mA Load: 600 Ω max. resolution: 12-bit
Synchronization method	Start-stop synchronization			---	
Baud rate	1,200/2,400/4,800/9,600/19,200 bps			---	
Transmission code	ASCII (7-bit) (see note 3)			---	

Note: 1. The maximum total cable length must not exceed the following limits.
RS-422: 500 m, RS-232C: 15 m, RS-485: 500 m

2. A maximum of 32 Temperature Controllers can be connected to one host computer using serial communications (RS-422 or RS-485).

3. 8-digit ASCII codes can be also used.

Operation

■ Sampling Period

The sampling period of the ES100-series Digital Temperature Controller is factory-set to 200 ms. If only the advanced PID control is used, the sampling period will vary with the Model as follows (with a baud rate of 9,600 bps for the Models incorporating a communications function):

Model	Sampling period	Model	Sampling period
ES100X-AAH	100 ms	ES100X-AAHFB	100 ms
ES100X-AAHFD	100 ms	ES100X-AAHFEB	100 ms
ES100X-AAWHFB	100 ms	ES100X-AAWHFEB	100 ms
ES100X-AAH01FE	100 ms	ES100X-AAH04FE	100 ms
ES100X-AAWH01FE	200 ms	ES100X-AAWH04FE	200 ms
ES100X-RRPFB	100 ms	ES100X-RRPFD	100 ms
ES100X-RRPFE	100 ms	ES100X-RRPWFB	100 ms
ES100X-RRPWFE	100 ms	ES100X-RRP01FE	100 ms
ES100X-RRP04FE	100 ms	ES100X-RRPW01FE	200 ms
ES100X-RRPW04FE	200 ms	ES100P-AAH	100 ms
ES100P-AAHFD	100 ms	ES100P-AAHFEB	100 ms
ES100P-AAWHFE	200 ms	ES100P-AAH01FE	200 ms
ES100P-AAH04FE	200 ms	ES100P-AAWH01FE	200 ms
ES100P-AAWH04FE	200 ms	ES100P-RRPFD	200 ms
ES100P-RRPFE	200 ms	ES100P-RRPWFE	200 ms
ES100P-RRP01FE	200 ms	ES100P-RRP04FE	200 ms
ES100P-RRPW01FE	200 ms	ES100P-RRPW04FE	200 ms

The control operation period is an important factor for the following control operations (refer to ES100X/ES100P Operation Manual for details):

- Heating/cooling control
- Cascade control
- Fuzzy control
- Analog I/O assignment
- Digital I/O assignment
- No. of events used
- No. of times that ON/OFF timer used
- Input type selector (linearization required or not)
- Terminal communications baud rate
- Use of digital I/O (BCD communication)

The control operation period can be checked with the monitor (character P229) in the check mode.

■ Product Inspection Sheet

Contact your OMRON representative if Product Inspection Sheet are required.

Dimensions

Note: All units are in millimeters unless otherwise indicated.

ES100X
ES100P

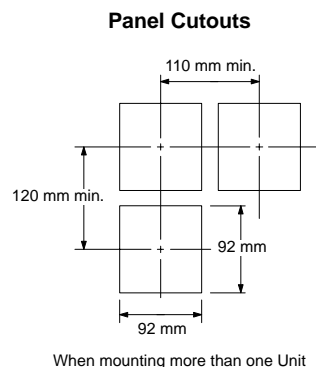
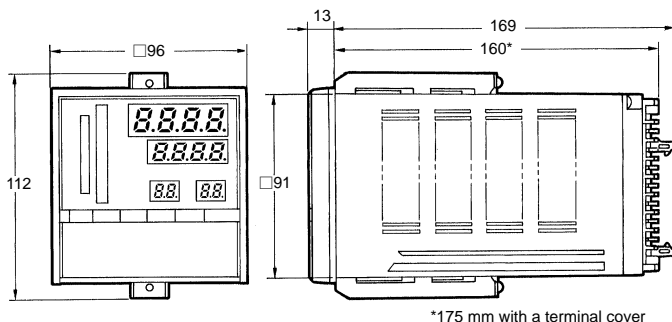
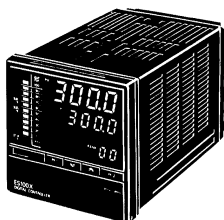

Y92A-96N Watertight Cover

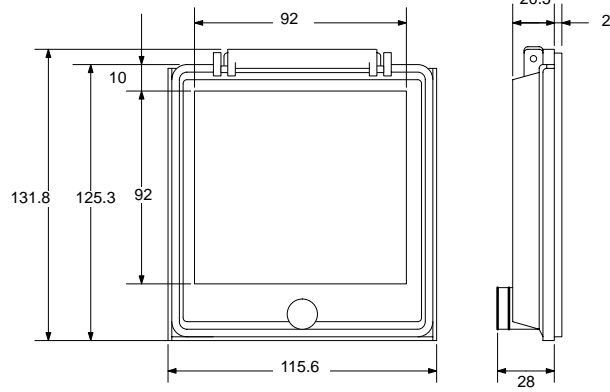
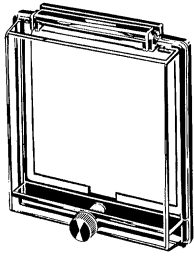

E53-COV01 Terminal Cover

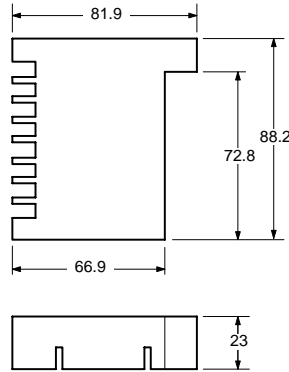
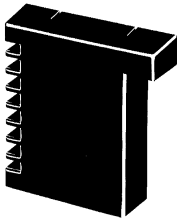

Installation

■ Factory Allocations of Terminal Functions Basic Model ES100□-AAH

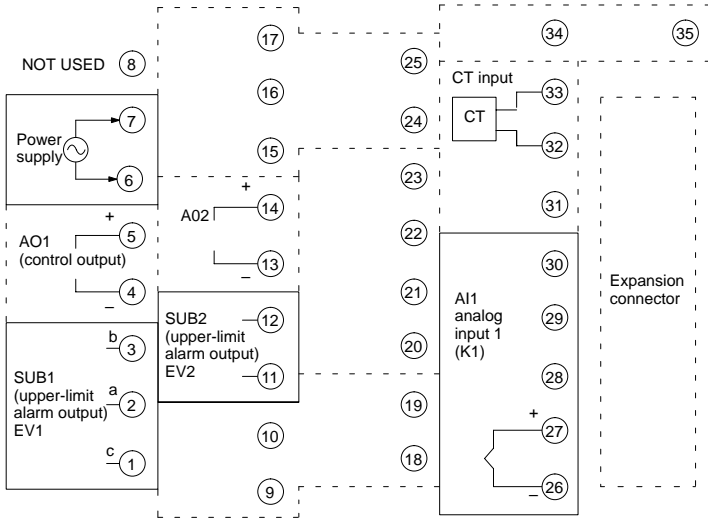

The allocation shown in the diagrams is applicable to all Basic Models.

Input K₁: -200 to 1,300°C

Control output: Heating control

Auxiliary output: Upper-limit deviation alarm (to be set with EV1 and EV2)

If the heating/cooling control mode is selected, AO1 is used for heating and AO2 is for cooling control output. To use AO1 and AO2, purchase Output Units.

Terminal Functions (Fixed) of Models other than Basic Models

Proportional Positioning Control
ES100□-RRP□□□□□

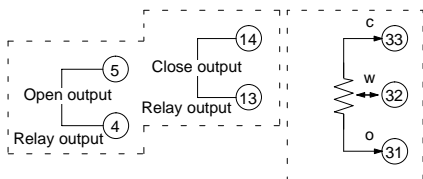

Upper Link RS-232C
ES100□-□□□□01□□

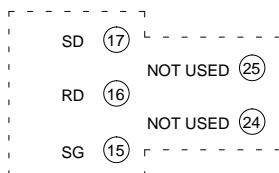

Upper Link RS422/485
ES100□-□□□□04□□

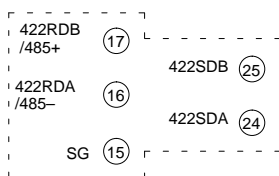

Terminal Functions (Possible to Relocate) of Models other than Basic Models

Input 2 (4 to 20 mA Remote Setting)
ES100□-□□W□□□□□

Initial setting: Use an input of 4 to 20 mA for remote setting. The setting will be effective in the SP mode.

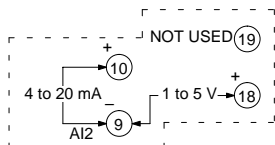

Transmission Output (AI1 Process Value)
ES100□-□□□□□□F□

Initial setting: The value measured by analog input 1 will be output in a range of 4 to 20 mA.

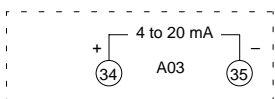

Digital I/O (Possible to Relocate) of Models other than Basic Models

Digital Input (Bank selectable) for ES100X
ES100X-□□□□□□□□B

Initial setting: Used to select a bank. The terminals operate as follows:

- BNK0: 2⁰
- BNK1: 2¹
- BNK2: 2²

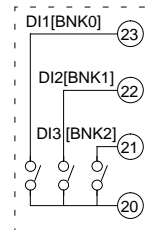

Digital I/O (Bank selectable) for ES100X
ES100X-□□□□□□□□D

Initial setting: Used to select a bank. The terminals operate as follows:

- BNK0: 2⁰
- BNK1: 2¹
- BNK2: 2²

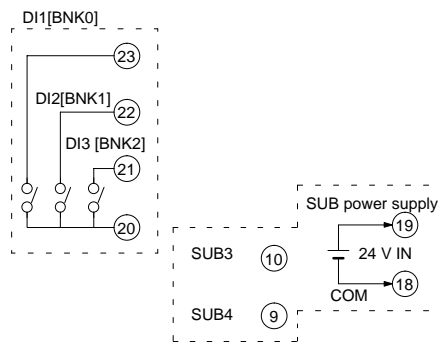

Expansion Digital I/O for ES100X
ES100X-□□□□□□□□E

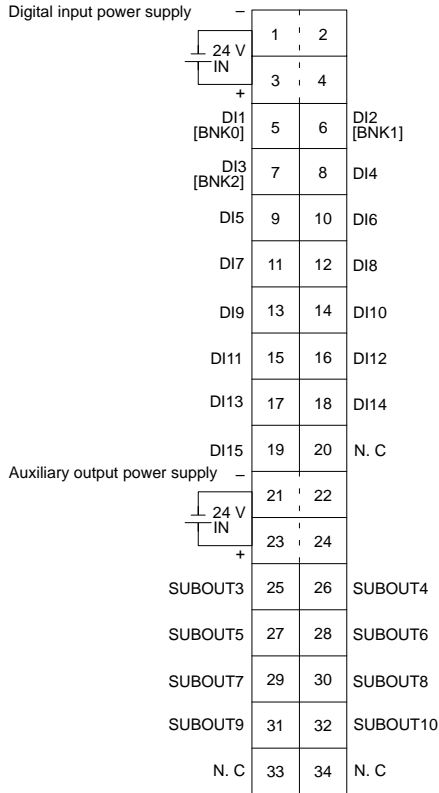

Expansion Digital I/O for ES100P
ES100P-□□□□□□□□E

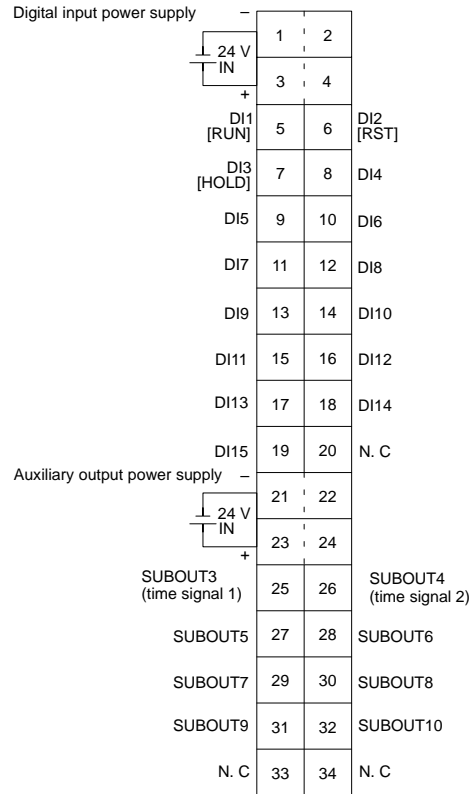

Digital I/O (Operation Instruction and Time Signal) for ES100P
ES100P-□□□□□□□□D

Initial setting: The RUN, RST, and HOLD input are used to operate the program. Time signals set by programs are output from the terminals.

DI1 through DI8 are digital input terminals and SUBOUT3 through SUBOUT10 are digital auxiliary output terminals, both sets of which can be allocated as instructed by the user's software. The terminals without allocation prior to shipping can be freely allocated as required by the user. DI9 through DI15 are special terminals for BCD communication.

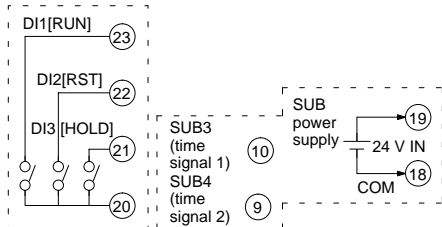

ES100 Documentation

Name	Catalog no.
ES100P Digital Controller User's Manual	H069
ES100X Digital Controller User's Manual	H070
ES100 ES/TOOLS Support Software for Windows User's Manual	H115
ES100 Digital Controller User's Manual (Communications Guide)	H072

ALL DIMENSIONS SHOWN ARE IN MILLIMETERS.

To convert millimeters into inches, multiply by 0.03937. To convert grams into ounces, multiply by 0.03527.

Cat. No. H058-E1-3 **In the interest of product improvement, specifications are subject to change without notice.**

OMRON Corporation

Industrial Automation Company

Measuring and Supervisory Controls Department
Shiokoji Horikawa, Shimogyo-ku,
Kyoto, 600-8530 Japan
Tel: (81)75-344-7080/Fax: (81)75-344-7189

Printed in Japan
0201-0.5M (0892) (A)